

Cilindri corsa breve Serie QP - QPR

1

MOVIMENTO

Serie QP: semplice e doppio effetto, magnetici
Serie QPR: antirotazione, a doppio effetto, magnetici
Ø 12, 16, 20, 25, 32, 40, 50, 63, 80, 100 mm



Sul profilo esterno sono ricavate parallelamente all'asse di scorrimento dello stelo sui tre lati le guide per applicare e posizionare i sensori per il rilevamento della posizione del pistone. Per quanto riguarda i QPR, le guide antirotazione incorporate li rendono adatti per operazioni di alimentazione e di prelievo di pezzi in dispositivi di manipolazione.

I cilindri a corsa breve Serie QP - QPR magnetici sono stati realizzati in dieci diversi alesaggi dal Ø 12 al Ø 100. La loro compattezza ne consente l'installazione in piccoli spazi. Le particolari soluzioni costruttive permettono l'impiego di questi cilindri anche con fissaggi a piedini e a cerniera.

CARATTERISTICHE GENERALI

Tipo di costruzione	Serie QP: a profilo compatto Serie QPR: compatti con guida antirotazione
Funzionamento	Serie QP: semplice e doppio effetto Serie QPR: doppio effetto
Materiali	corpo: AL anodizzato stelo: acciaio INOX rullato guarnizioni pistone: PU guarnizioni stelo: PU (Ø 12 + 25 mm) - NBR (Ø 32 + 100 mm)
Temperatura d'esercizio	0°C + 80°C (con aria secca -20°C)
Tipo di fissaggio	per mezzo di viti o ancoraggi
Pressione d'esercizio	1 + 10 bar (doppio effetto) 2 + 10 bar (semplice effetto)
Fluido	aria filtrata, senza lubrificazione. Nel caso si utilizzasse aria lubrificata, si consiglia olio ISOVG32 e di non interrompere mai la lubrificazione.
Corse (min-max):	Serie QP: 1 + 150 mm (Ø 12 + 25) - 1 + 200 mm (Ø 32 + 100) Serie QPR: 1 + 50 mm (Ø 12) - 1 + 75 mm (Ø 16) - 1 + 100 mm (Ø 20 + 100)
Corse	la corsa minima per l'utilizzo dei sensori è di 10 mm
Alesaggi	Ø 12, 16, 20, 25, 32, 40, 50, 63, 80, 100

TABELLA CORSE STANDARD PER CILINDRI CORSA BREVE SERIE QP E QPR

■ = Doppio effetto ✕ = Semplice effetto ● = Antirotazione

CORSE STANDARD

Ø	5	10	15	20	25	30	35	40	45	50	60	75	80	100
12	■ ✕ ●	■ ✕ ●	■ ✕ ●	■ ✕	■ ✕ ●	■ ●	■	■	■					
16	■ ✕ ●	■ ✕ ●	■ ✕ ●	■ ✕ ●	■ ✕ ●	■ ●	■ ●	■ ●	■ ●	■ ●	■ ●	■ ●	■	■
20	■ ✕ ●	■ ✕ ●	■ ✕ ●	■ ✕ ●	■ ✕ ●	■ ●	■ ●	■ ●	■ ●	■ ●	■ ●	■ ●	■ ●	■ ●
25	■ ✕ ●	■ ✕ ●	■ ✕ ●	■ ✕ ●	■ ✕ ●	■ ●	■ ●	■ ●	■ ●	■ ●	■ ●	■ ●	■ ●	■ ●
32	■ ✕ ●	■ ✕ ●	■ ✕ ●	■ ✕ ●	■ ✕ ●	■ ●	■ ●	■ ●	■ ●	■ ●	■ ●	■ ●	■ ●	■ ●
40	■ ✕ ●	■ ✕ ●	■ ✕ ●	■ ✕ ●	■ ✕ ●	■ ●	■ ●	■ ●	■ ●	■ ●	■ ●	■ ●	■ ●	■ ●
50	■ ✕ ●	■ ✕ ●	■ ✕ ●	■ ✕ ●	■ ✕ ●	■ ●	■ ●	■ ●	■ ●	■ ●	■ ●	■ ●	■ ●	■ ●
63	■ ✕ ●	■ ✕ ●	■ ✕ ●	■ ✕ ●	■ ✕ ●	■ ●	■ ●	■ ●	■ ●	■ ●	■ ●	■ ●	■ ●	■ ●
80	■ ✕ ●	■ ✕ ●	■ ✕ ●	■ ✕ ●	■ ✕ ●	■ ●	■ ●	■ ●	■ ●	■ ●	■ ●	■ ●	■ ●	■ ●
100	■ ✕ ●	■ ✕ ●	■ ✕ ●	■ ✕ ●	■ ✕ ●	■ ●	■ ●	■ ●	■ ●	■ ●	■ ●	■ ●	■ ●	■ ●

ESEMPIO DI CODIFICA

QP	2	A	050	A	050
QP	SERIE QP = standard QPR = antirotazione		SIMBOLI PNEUMATICI CS09 CD07 CD14		
2	FUNZIONAMENTO 1 = semplice effetto, molla anteriore (solo serie QP) 2 = doppio effetto 3 = doppio effetto, stelo passante				
A	CARATTERISTICHE MATERIALI A = stelo acciaio INOX rullato - profilo AL				
050	ALESAGGIO 012 = 12 mm 016 = 16 mm 020 = 20 mm 025 = 25 mm 032 = 32 mm 040 = 40 mm 050 = 50 mm 063 = 63 mm 080 = 80 mm 100 = 100 mm				
A	TIPO COSTRUTTIVO A = standard				
050	CORSA (vedi tabella) = standard V = guarnizione stelo in FKM W = tutte le guarnizioni in FKM (escluso Ø 12)				

SIMBOLI PNEUMATICI

I simboli pneumatici indicati nell'ESEMPIO DI CODIFICA sono riportati di seguito.

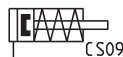
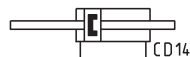

ACCESSORI CILINDRI CORSA BREVE SERIE QP

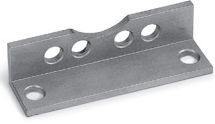

Ancoraggio a piedini
Mod. B

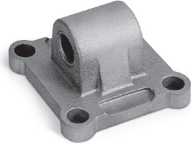

Ancoraggio a cerniera
maschio Mod. L



Tutti gli accessori sono forniti separatamente al cilindro.

MOMENTO TORCENTE IN FUNZIONE DELLA CORSA C

1

MOVIMENTO

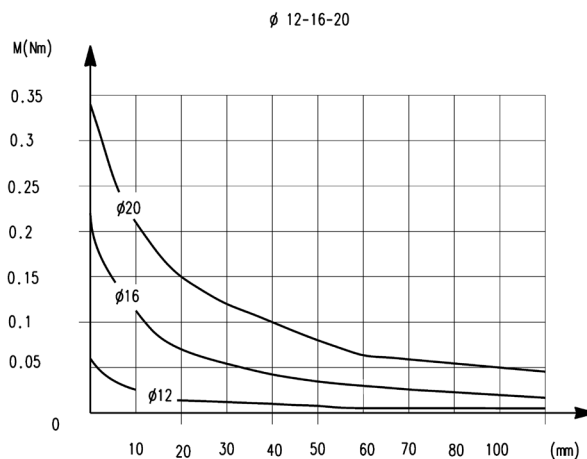
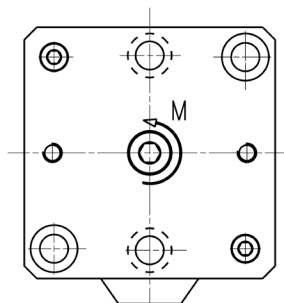

MOMENTO TORCENTE IN FUNZIONE DELLA CORSA C

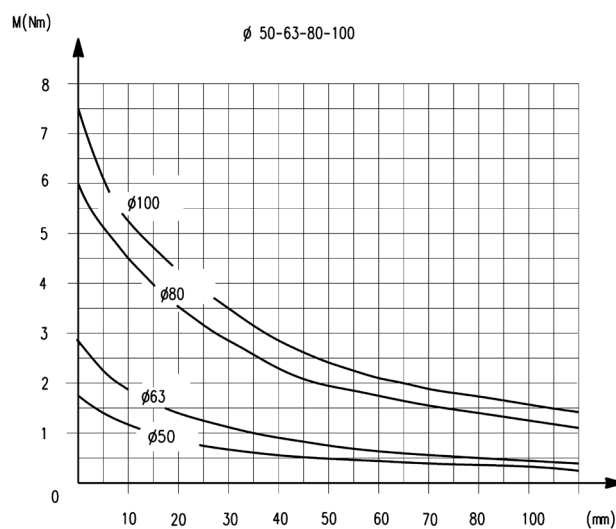
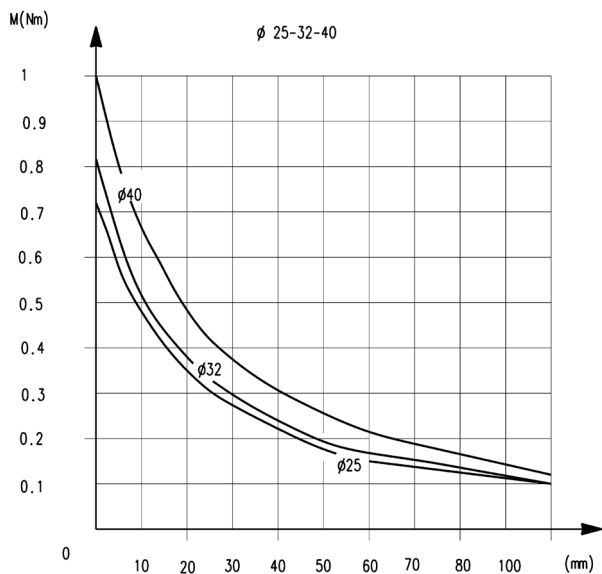

CARICO TRASVERSALE IN FUNZIONE DELLA SPORGENZA " X "

1

MOVIMENTO

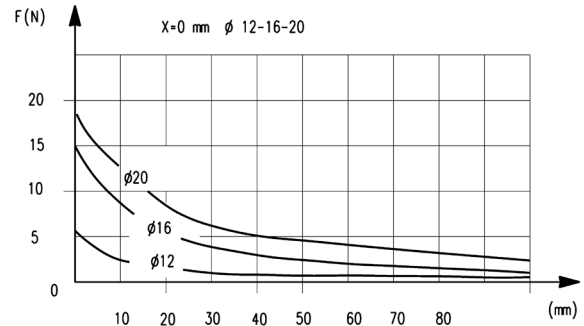
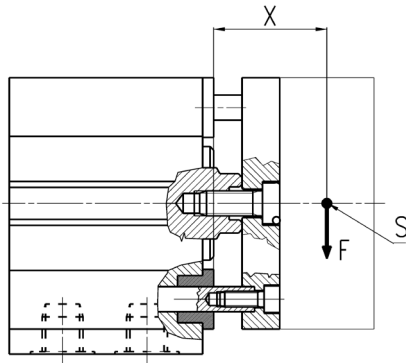

CARICO TRASVERSALE IN FUNZIONE DELLA SPORGENZA " X "

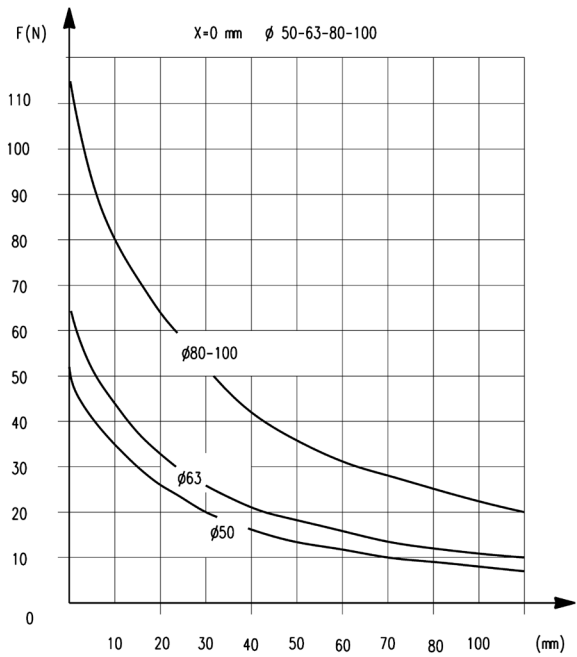
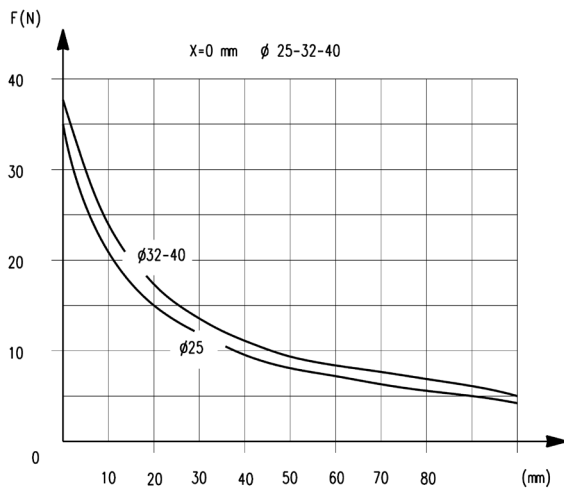

F = forza trasversale

Cilindri corsa breve Serie QP

NB: La battuta meccanica di fine corsa dei cilindri deve essere predisposta esternamente. Per i cilindri a semplice effetto ϕ 12, 16, 20 e 25 aumentare di 5 mm le quote G+, G1+ e N+.

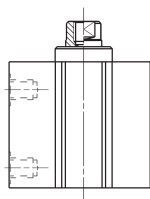
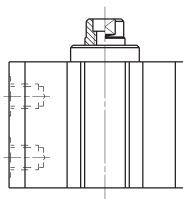
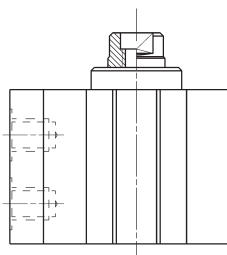
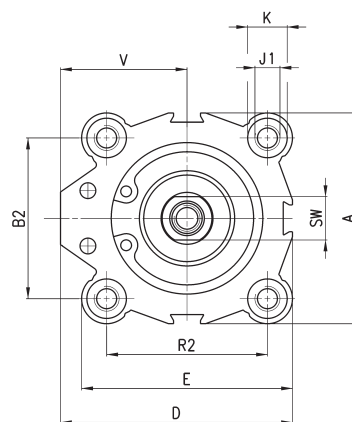
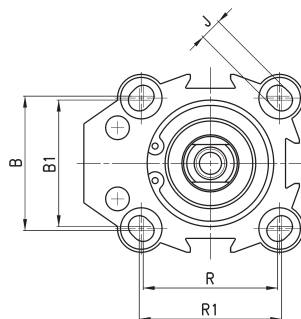
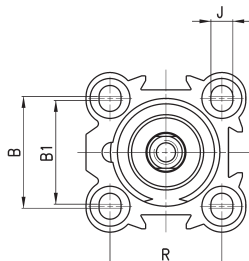
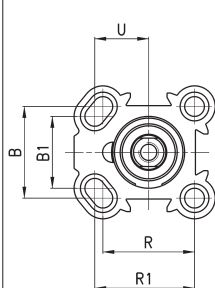
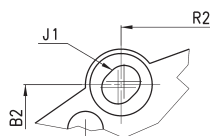
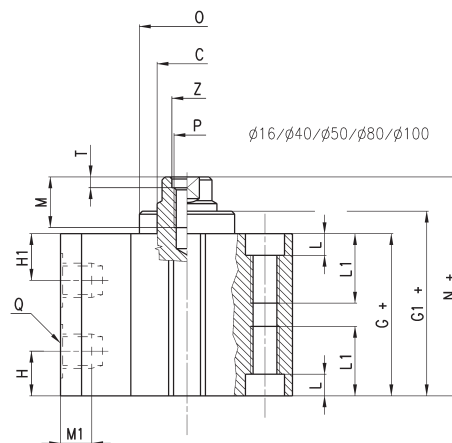

+ = sommare la corsa

 ϕ 12/ ϕ 20

 ϕ 25

 ϕ 32/ ϕ 63

 ϕ 16/ ϕ 40/ ϕ 50/ ϕ 80/ ϕ 100

INGOMBRI

ϕ	A	B	B1	B2	ϕ C	D	E	G+	G1+	H1	H	J	J1	K	L	L1	M	M1	N+	ϕ O	P	Q	R	R1	R2	SW	T	U	V	Z
12	23.8	15.5	13	-	6	25	25	29.6	29.6	12.3	7.8	3.5	-	5.8	3	-	5.5	4.5	32.9	-	M3	M5	15.5	16.75	-	5	-	9	13.15	-
16	29	20	-	-	8	29	29	32	32.4	10.9	8.7	3.5	-	5.8	3	-	8	4.5	36.4	16.6	M4	M5	20	-	-	6	-	-	14.5	-
20	37	25.5	20	-	10	39.25	39.25	31.2	31.7	9.8	9.8	5.5	-	9	6	-	8	4.5	36	19.5	M6	M5	25.5	27.75	-	8	-	15	20.75	-
25	40	28	26	-	10	40	40	32.1	33.5	8	6.9	5.5	-	10	5.5	-	8	4.5	37.5	22	M6	M5	28	-	-	8	-	-	20	-
32	45	34	32	33	12	55.5	47	39.5	40	9.5	9.5	5.5	M8	10.5	6	21	10	7.5	44	23.5	M6	G1/8	34	36	35	10	2.5	-	32	7
40	52	-	-	40	16	57	52	42.4	43.4	10.7	10.7	5.5	M8	9	6	21	13.5	7.5	47.9	29.6	M8	G1/8	-	-	40	13	3.5	-	31	8.5
50	64	-	-	50	16	72	64	42.2	44	11.2	11.2	6.5	M8	10.5	6	21	13.5	9	48.4	37.5	M8	G1/4	-	-	50	13	3.5	-	40	8.5
63	80	62	60	61	20	88	80	49.5	50.1	13	13	8.5	M12	15	8.5	31.5	13.5	9	54	50	M8	G1/4	60	62	61	17	4	-	48	8.5
80	98	-	-	77	25	104	98	57.5	58.1	16.2	16.2	10.5	M12	17	10.5	31.5	15	10.5	63.5	62	M16	G3/8	-	-	77	22	4	-	55	16.5
100	117	-	-	94	25	123.5	117	68.5	69.1	20.3	20.3	10.5	M12	17	10.5	31.5	15	10.5	74.5	80	M16	G3/8	-	-	94	22	4	-	65	16.5

Cilindri corsa breve Serie QP

NB: La battuta meccanica di fine corsa dei cilindri deve essere predisposta esternamente.



+ = sommare la corsa
++ = sommare 2 volte la corsa

∅12/∅20

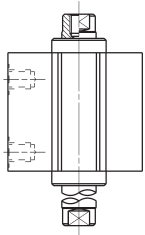

∅25

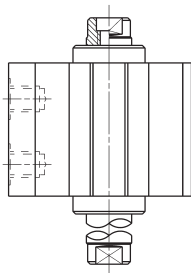

∅32/∅63

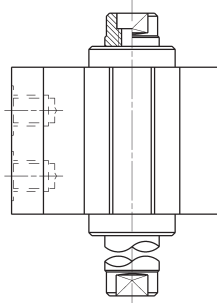

∅16/∅40/∅50/∅80/∅100

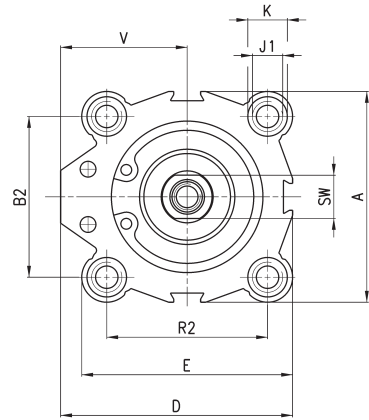
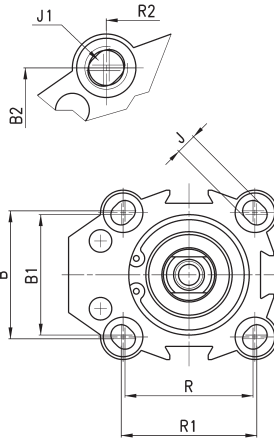
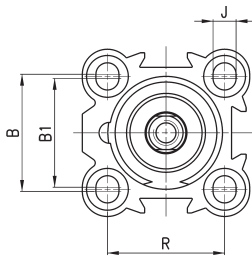
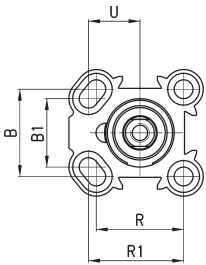
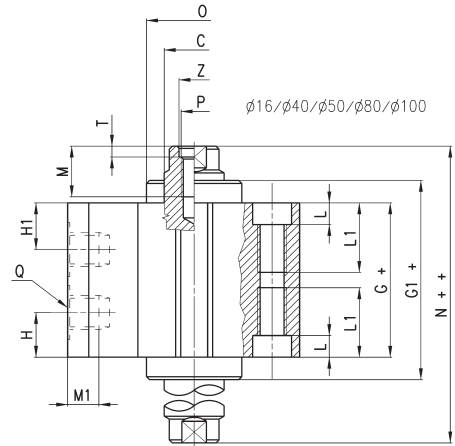

INGOMBRI

∅	A	B	B1	B2	∅C ^{h8}	D	E	G+	G1+	H1	H	J	J1	K	L	L1	M	M1	N++	∅O	P	Q	R	R1	R2	SW	T	U	V	Z
12	23.8	15.5	13	-	6	25	25	34.5	34.5	12.3	12.3	3.5	-	5.8	3	-	5.5	4.5	41	-	M3	M5	15.5	16.75	-	5	-	9	13.15	-
16	29	20	-	-	8	29	29	38	38.8	10.9	10.9	3.5	-	5.8	3	-	8	4.5	46.4	16.6	M4	M5	20	-	-	6	-	-	14.5	-
20	37	25.5	20	-	10	39.25	39.25	38.1	39.1	9.8	9.8	5.5	-	9	6	-	8	4.5	47.7	19.5	M6	M5	25.5	27.75	-	8	-	15	20.75	-
25	40	28	26	-	10	40	40	36.3	39.1	8	8	5.5	-	10	5.5	-	8	4.5	47.1	22	M6	M5	28	-	-	8	-	-	20	-
32	45	34	32	33	12	55.5	47	39.5	40.5	9.5	9.5	5.5	M8	10.5	6	21	10	7.5	48.5	23.5	M6	G1/8	34	36	35	10	2.5	-	32	7
40	52	-	-	40	16	57	52	42.4	44.4	10.7	10.7	5.5	M8	9	6	21	13.5	7.5	53.4	29.6	M8	G1/8	-	-	40	13	3.5	-	31	8.5
50	64	-	-	50	16	72	64	42.2	45.8	11.2	11.2	6.5	M8	10.5	6	21	13.5	9	54.8	37.5	M8	G1/4	-	-	50	13	3.5	-	40	8.5
63	80	62	60	61	20	88	80	49.5	50.7	13	13	8.5	M12	15	8.5	31.5	13.5	9	58.5	50	M8	G1/4	60	62	61	17	4	-	48	8.5
80	98	-	-	77	25	104	98	57.5	58.7	16.2	16.2	10.5	M12	17	10.5	31.5	15	10.5	69.5	62	M16	G3/8	-	-	77	22	4	-	55	16.5
100	117	-	-	94	25	123.5	117	68.5	69.7	20.3	20.3	10.5	M12	17	10.5	31.5	15	10.5	80.5	80	M16	G3/8	-	-	94	22	4	-	65	16.5

Cilindri corsa breve Serie QPR

NB: La battuta meccanica di fine corsa dei cilindri deve essere predisposta esternamente.

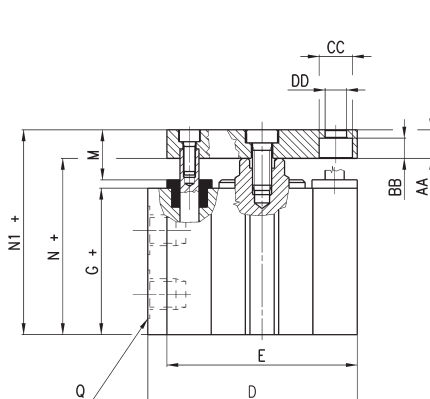
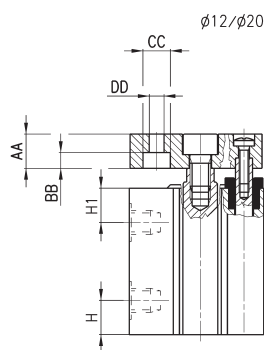
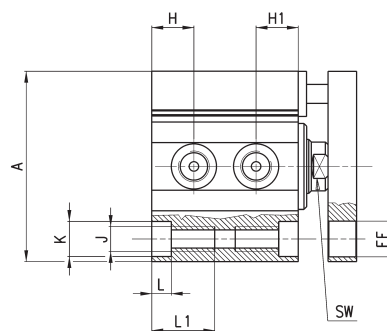
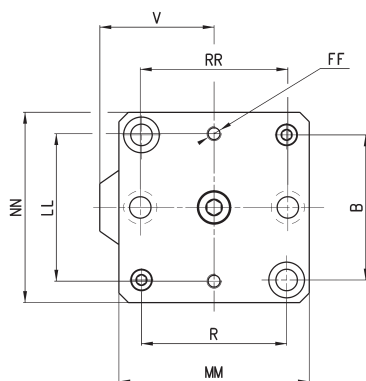
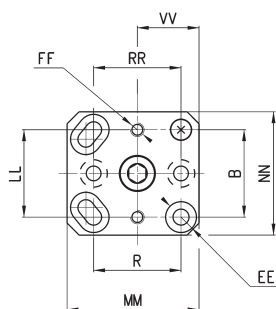

+ = sommare la corsa

 $\phi 16/\phi 25/\phi 32/\phi 40/\phi 50/\phi 63/\phi 80/\phi 100$

INGOMBRI

Ø	A	B	D	E	G+	H1	H	J	K	L	L1	N+	N1+	Q	R	SW	V	AA	BB	φCC	φDD	EE	FF	LL	MM	NN	RR	VV
12	23.8	15.5	25	25	29.6	12.3	7.8	3.5	5.8	3	-	32.9	37.9	M5	15.5	5	13.15	5	3.5	6.2	3.2	5.8	M3	15.5	25	24	15.5	12
16	29	20	29	29	32	10.9	8.7	3.5	5.8	3	-	36.4	41.4	M5	20	6	14.5	5	3.5	6.2	3.2	6.5	M3	20	28	28	20	-
20	37	25.5	39.25	39.25	31.2	9.8	9.8	5.5	9	6	-	36	46	M5	25.5	8	20.75	10	4.6	8	4.2	9	M4	25.5	38.5	36	25.5	18
25	40	28	40	40	32.1	8	6.9	5.5	10	5.5	-	37.5	47.5	M5	28	8	20	10	4.6	8	4.2	10	M4	27	40	40	28	-
32	45	33	55.5	47	39.5	9.5	9.5	M8	10.5	6	21	44	54	G1/8	35	10	32	10	6	9	5.5	9	M5	32	47	45	36	-
40	52	40	57	52	42.4	10.7	10.7	M8	9	6	21	47.9	57.9	G1/8	40	13	31	10	6	9	5.5	9	M5	40	52	50	40	-
50	64	50	72	64	42.2	11.2	11.2	M8	10.5	6	21	48.4	60.4	G1/4	50	13	40	12	6.8	10.5	6.5	10	M6	50	65	65	50	-
63	80	61	88	80	49.5	13	13	M12	15	8.5	31.5	54	66	G1/4	61	17	48	12	8.5	14	9	15	M6	62	80	80	62	-
80	98	77	104	98	57.5	16.2	16.2	M12	17	10.5	31.5	63.5	78.5	G3/8	77	22	55	15	10	16.5	11	17	M8	77	100	100	77	-
100	117	94	123.5	117	68.5	20.3	20.3	M12	17	10.5	31.5	74.5	89.5	G3/8	94	22	65	15	10	16.5	11	17	M8	94	115	115	94	-

Cilindri corsa breve Serie QPR - stelo passante

NB: La battuta meccanica di fine corsa dei cilindri a stelo passante deve essere predisposta esternamente.



+ = sommare la corsa
++ = sommare 2 volte la corsa

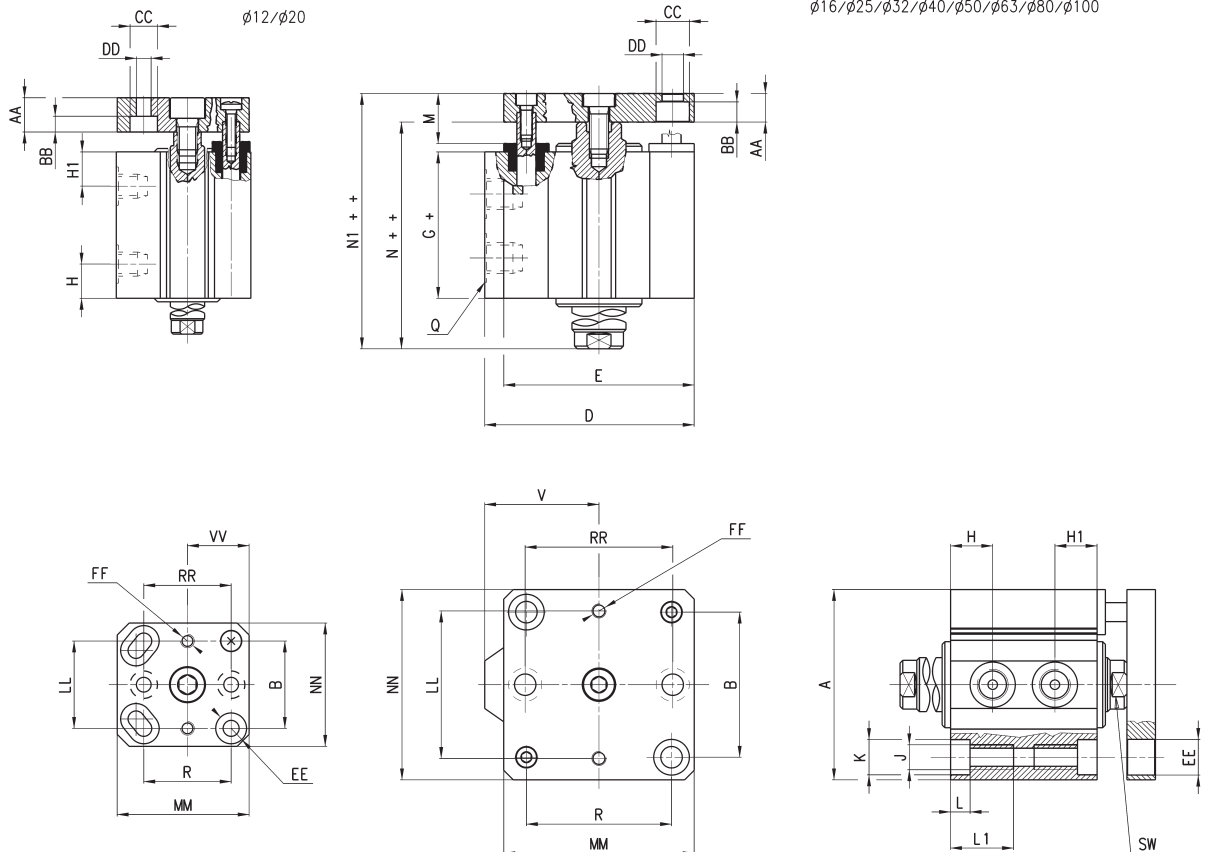

INGOMBRI

Ø	A	B	D	E	G+	H1	H	J	K	L	L1	N++	N1++	Q	R	SW	V	AA	BB	CC	DD	EE	FF	LL	MM	NN	RR	VV
12	23.8	15.5	25	25	37.3	12.3	12.3	3.5	5.8	3	-	41	46	M5	15.5	5	13.15	5	3.5	6.2	3.2	5.8	M3	15.5	25	24	15.5	12
16	29	20	29	29	38	10.9	10.9	3.5	5.8	3	-	47	52	M5	20	6	14.5	5	3.5	6.2	3.2	6.5	M3	20	28	28	20	-
20	37	25.5	39.25	39.25	38.1	9.8	9.8	5.5	9	6	-	47.7	57.7	M5	25.5	8	20.75	10	4.6	8	4.2	9	M4	25.5	38.5	36	25.5	18
25	40	28	40	40	36.3	8	8	5.5	10	5.5	-	47.1	57.1	M5	28	8	20	10	4.6	8	4.2	10	M4	27	40	40	28	-
32	45	33	55.5	47	39.5	9.5	9.5	M8	10.5	6	21	48.5	58.5	G1/8	35	10	32	10	6	9	5.5	9	M5	32	47	45	36	-
40	52	40	57	52	42.4	10.7	10.7	M8	9	6	21	53.4	63.4	G1/8	40	13	31	10	6	9	5.5	9	M5	40	52	50	40	-
50	64	50	72	64	42.2	11.2	11.2	M8	10.5	6	21	54.8	66.8	G1/4	50	13	40	12	6.8	10.5	6.5	10	M6	50	65	65	50	-
63	80	61	88	80	49.5	13	13	M12	15	8.5	31.5	58.5	70.5	G1/4	61	17	48	12	8.5	14	9	15	M6	62	80	80	62	-
80	98	77	104	98	57.5	16.2	16.2	M12	17	10.5	31.5	69.5	84.5	G3/8	77	22	55	15	10	16.5	11	17	M8	77	100	100	77	-
100	117	94	123.5	117	68.5	20.3	20.3	M12	17	10.5	31.5	80.5	95.5	G3/8	94	22	65	15	10	16.5	11	17	M8	94	115	115	94	-

Ancoraggio a cerniera maschio Mod. L

Materiale: Alluminio

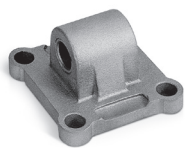
 La fornitura comprende:
 N° 1 cerniera
 N° 4 viti

+ = sommare la corsa

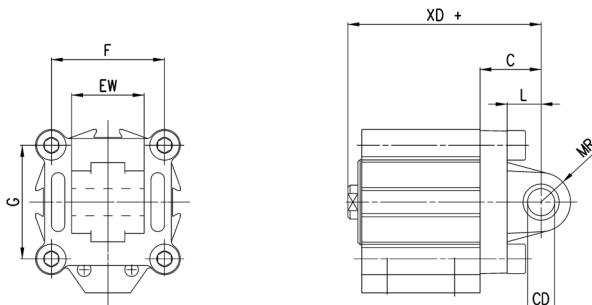

INGOMBRI									
Mod.	∅	CD ^{H9}	MR	L	C	XD+	F	G	EW
L-QP-32	32	10	9	12	22	66	33	35	26
L-QP-40	40	12	13	15	25	73	40	40	28
L-QP-50	50	12	13	15	27	75,5	50	50	32
L-QP-63	63	16	15	20	32	86	61	61	40
L-QP-80	80	16	15	24	36	99,5	77	77	50
L-QP-100	100	20	18	29	41	115,5	94	94	60

Ancoraggio a piedini Mod. B

Materiale: Acciaio zincato

 La fornitura comprende:
 N° 2 piedini
 N° 4 viti

+ = sommare la corsa

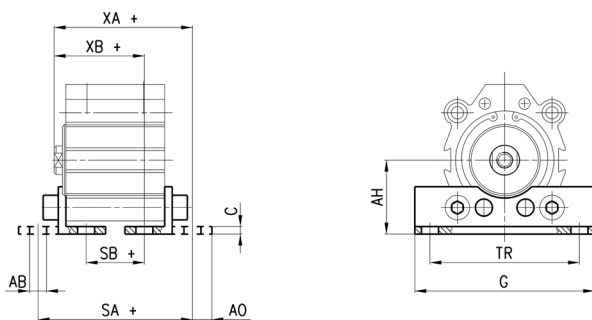

INGOMBRI											
Mod.	∅	C	SA+	XA+	SB+	XB+	TR	G	AB	AH	AO
B-QP-32	32	3	61.9	55.2	23.1	35.8	57	71	6.6	30	8.8
B-QP-40	40	3	64.8	59.1	26	39.7	64	78	6.6	33	8.8
B-QP-50	50	4	71.6	63.1	20.8	37.7	79	95	9	39	10.3
B-QP-63	63	4	81.9	70.2	25.1	41.8	95	113	11	46	13.8
B-QP-80	80	6	96.5	83	30.5	49	118	140	13	59	10.5
B-QP-100	100	6	114.5	97.5	22.5	51.5	137	162	13	71	17