

Pinza pneumatica a 2 griffe ad azione parallela autocentrante (serie MG)

- Azionamento a doppio effetto.
- Costruzione robusta: grande durata e affidabilità senza manutenzione.
- Possibilità di scelta su un'ampia gamma di corse e forze di serraggio.
- Forza di serraggio costante su tutta la corsa in apertura ed in chiusura.
- Profilo piatto.
- Predisposta per sensori induttivi.
- Grasso alimentare FDA-H1.

2-jaw parallel self-centering pneumatic gripper (series MG)

- Double acting.
- The rugged construction lends itself to heavy duty applications for a trouble free long life without maintenance.
- Wide choice of gripping force and stroke length options.
- The gripping force is constant on both directions along total stroke.
- Flat profile.
- Prepared for mounting inductive sensors.
- FDA-H1 food-grade grease.

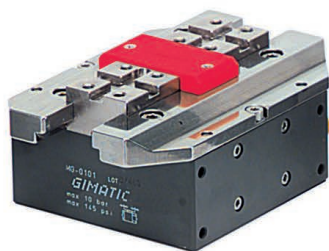

MG-0100



MG-0101



MG-0102

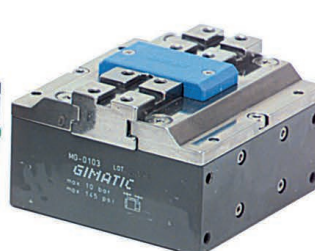

MG-0103



MG-0075



MG-0076

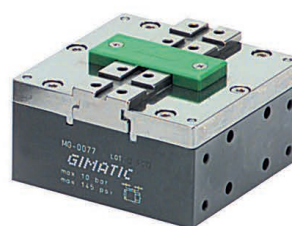

MG-0077



MG-0050



MG-0051



MG-0052



MG-0025



MG-0026



MG-0027



MG-0010



MG-0011



MG-0012

	MG-0010	MG-0011	MG-0012
Fluido <i>Medium</i>	Aria compressa filtrata, lubrificata / non lubrificata <i>Filtered, lubricated / non lubricated compressed air</i>		
Pressione di esercizio <i>Operating pressure range</i>	2÷8 bar		
Temperatura di esercizio <i>Operating temperature range</i>	5÷60 °C.		
Forza di serraggio per griffa a 6 bar <i>Gripping force at 6 bar on each jaw</i>	35 N	18 N	70 N
Forza di serraggio totale a 6 bar <i>Total gripping force at 6 bar</i>	70 N	36 N	140 N
Corsa totale <i>Total stroke</i> (±0.3 mm)	5.3 mm	9.3 mm	2.5 mm
Frequenza max funzionamento continuativo <i>Maximum working frequency</i>	3 Hz		
Consumo d'aria per ciclo <i>Cycle air consumption</i>	1.5 cm ³		
Tempo di chiusura senza carico <i>Closing time without load</i>	0.03 s		
Ripetibilità <i>Repetition accuracy</i>	0.02 mm		
Peso <i>Weight</i>	60 g	65 g	60 g

Dimensioni (mm) / Dimensions (mm)

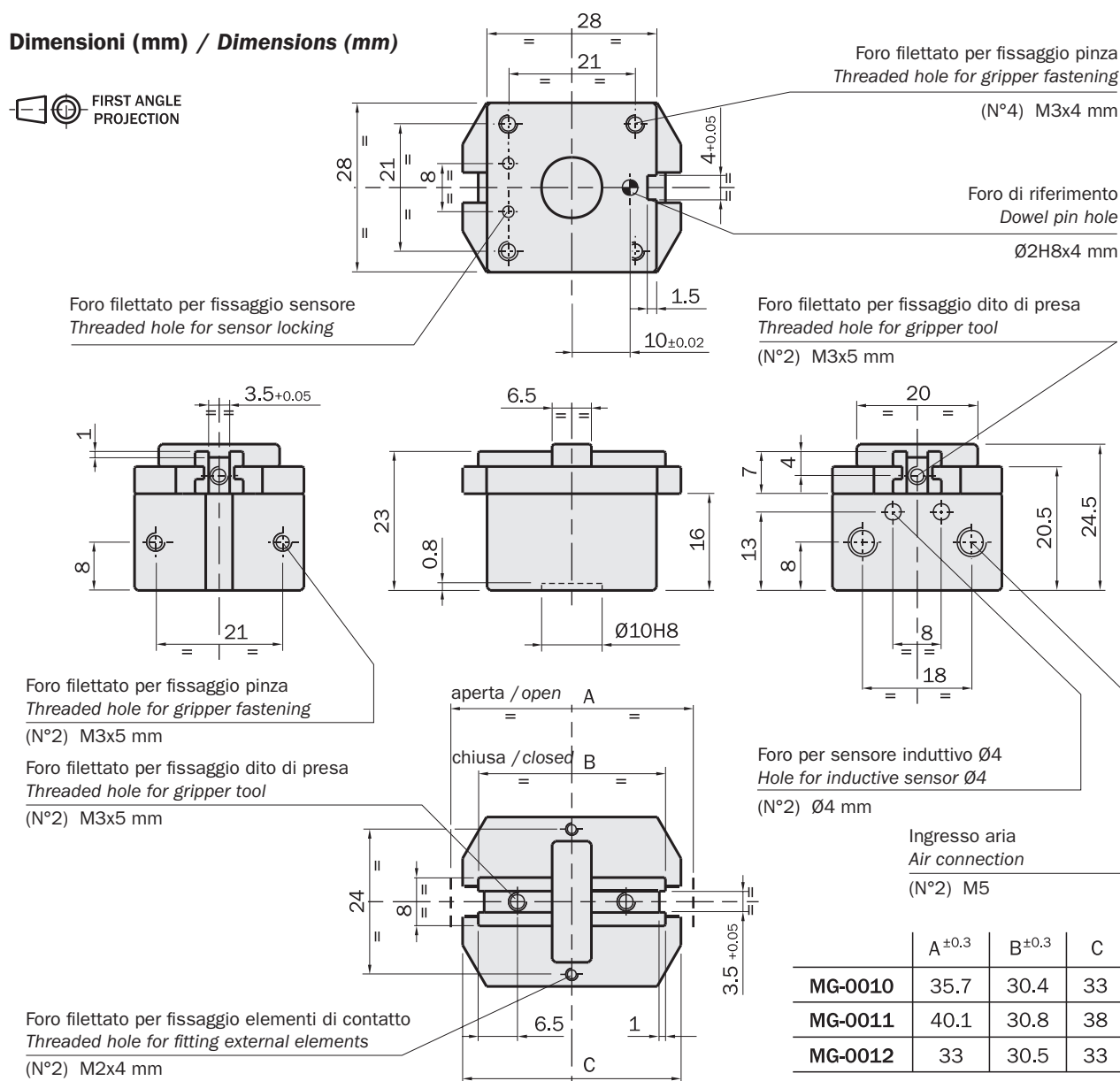

	A ^{±0.3}	B ^{±0.3}	C
MG-0010	35.7	30.4	33
MG-0011	40.1	30.8	38
MG-0012	33	30.5	33

	MG-0025	MG-0026	MG-0027
Fluido Medium	Aria compressa filtrata, lubrificata / non lubrificata Filtered, lubricated / non lubricated compressed air		
Pressione di esercizio Operating pressure range	2÷8 bar		
Temperatura di esercizio Operating temperature range	5÷60 °C.		
Forza di serraggio per griffa a 6 bar Gripping force at 6 bar on each jaw	70 N	40 N	130 N
Forza di serraggio totale a 6 bar Total gripping force at 6 bar	140 N	80 N	260 N
Corsa totale Total stroke (±0.3 mm)	8.7 mm	14.8 mm	4 mm
Frequenza max funzionamento continuativo Maximum working frequency	3 Hz		
Consumo d'aria per ciclo Cycle air consumption	3.4 cm ³		
Tempo di chiusura senza carico Closing time without load	0.05 s		
Ripetibilità Repetition accuracy	0.02 mm		
Peso Weight	160 g	170 g	150 g

Dimensioni (mm) / Dimensions (mm)

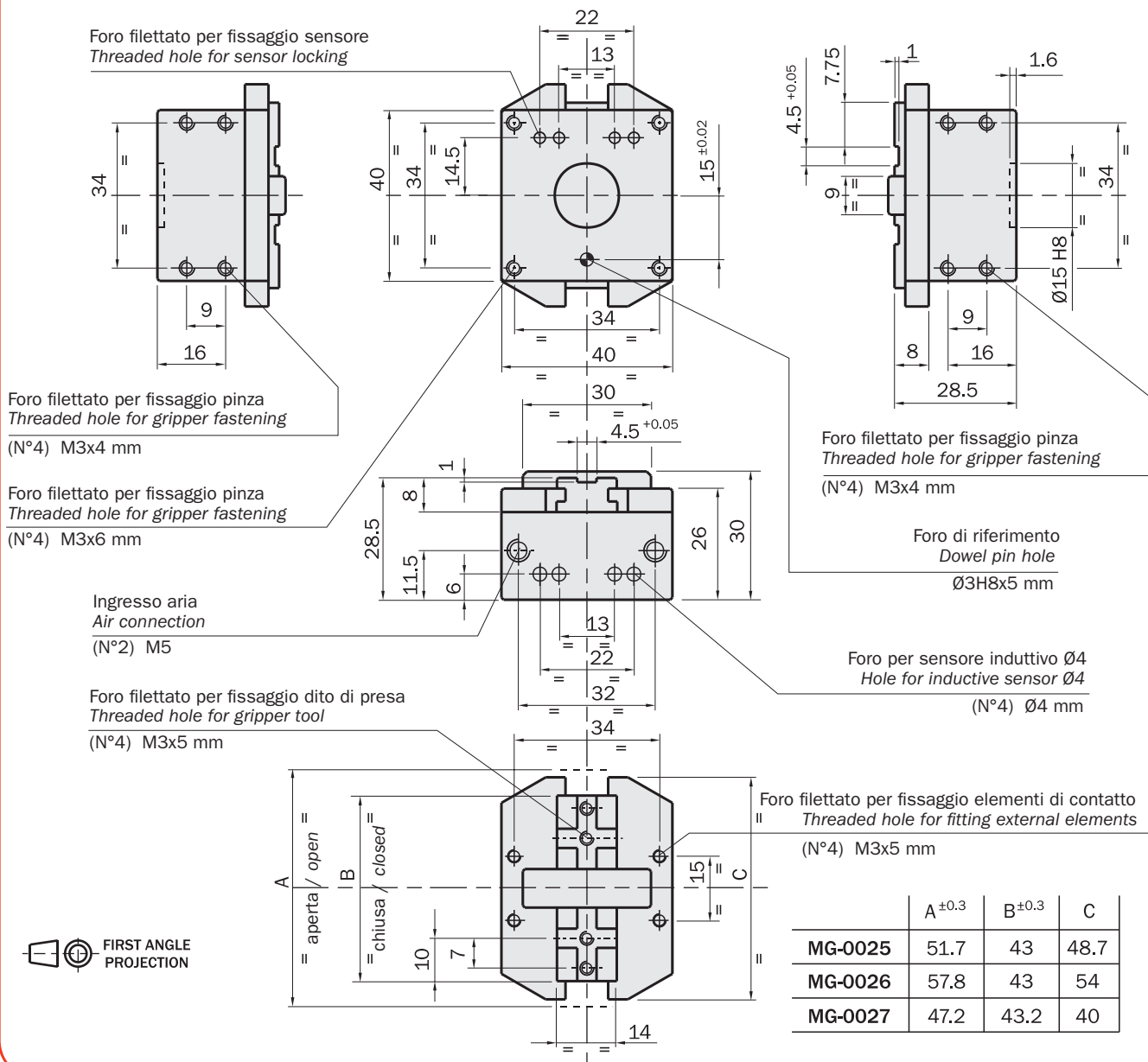

	MG-0050	MG-0051	MG-0052
Fluido Medium	Aria compressa filtrata, lubrificata / non lubrificata Filtered, lubricated / non lubricated compressed air		
Pressione di esercizio Operating pressure range	2÷8 bar		
Temperatura di esercizio Operating temperature range	5÷60 °C.		
Forza di serraggio per griffa a 6 bar Gripping force at 6 bar on each jaw	160 N	90 N	300 N
Forza di serraggio totale a 6 bar Total gripping force at 6 bar	320 N	180 N	600 N
Corsa totale Total stroke (±0.3 mm)	11.4 mm	19.8 mm	5.4 mm
Frequenza max funzionamento continuativo Maximum working frequency	3 Hz		
Consumo d'aria per ciclo Cycle air consumption	12 cm ³		
Tempo di chiusura senza carico Closing time without load	0.09 s		
Ripetibilità Repetition accuracy	0.02 mm		
Peso Weight	370 g	380 g	350 g

Dimensioni (mm) / Dimensions (mm)

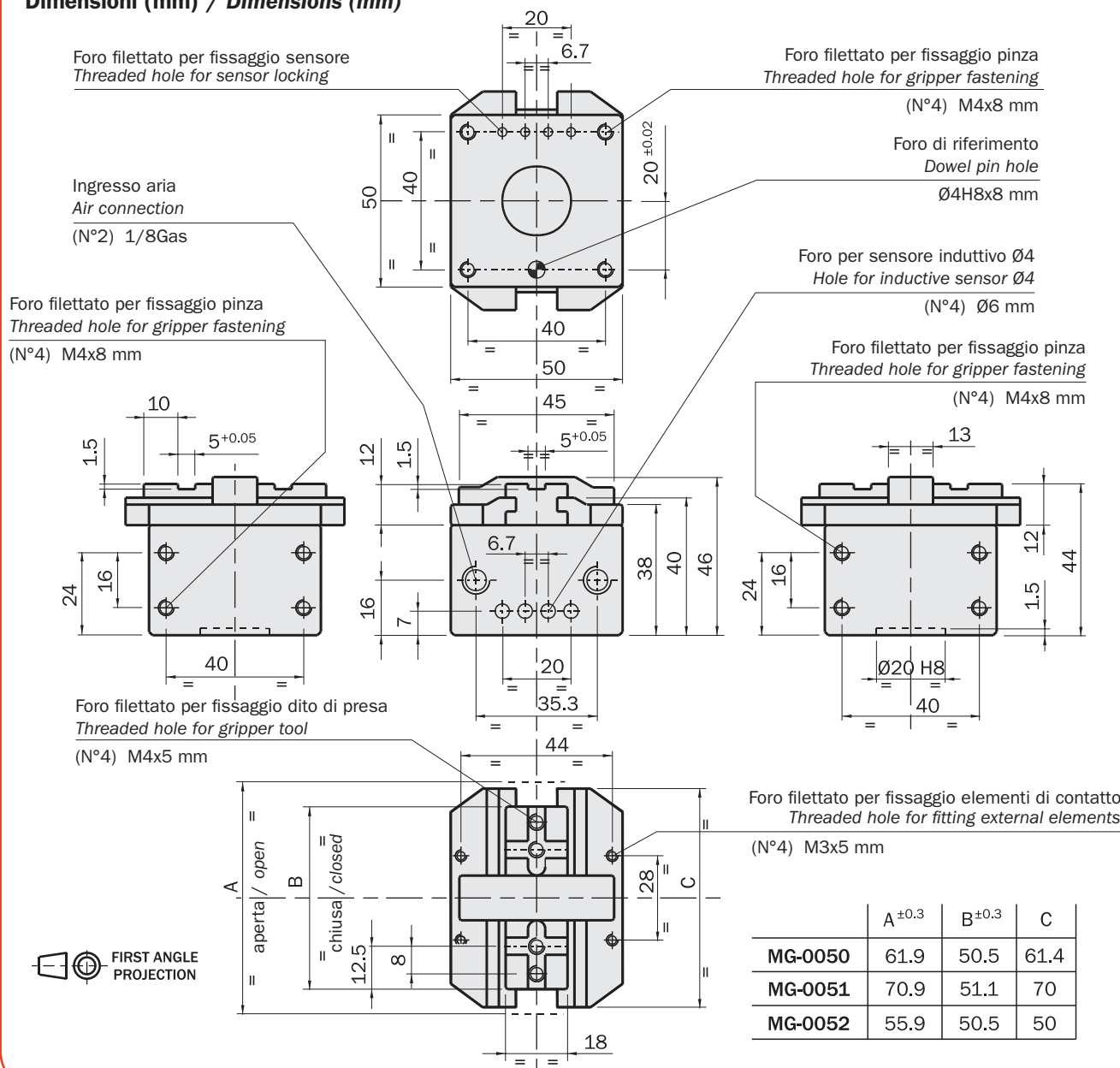

	MG-0075	MG-0076	MG-0077
Fluido Medium	Aria compressa filtrata, lubrificata / non lubrificata Filtered, lubricated / non lubricated compressed air		
Pressione di esercizio Operating pressure range	2÷8 bar		
Temperatura di esercizio Operating temperature range	5÷60 °C.		
Forza di serraggio per griffa a 6 bar Gripping force at 6 bar on each jaw	250 N	160 N	540 N
Forza di serraggio totale a 6 bar Total gripping force at 6 bar	500 N	320 N	1080 N
Corsa totale (±0.3 mm) Total stroke	19.1 mm	32.9 mm	9 mm
Frequenza max funzionamento continuativo Maximum working frequency	2 Hz		
Consumo d'aria per ciclo Cycle air consumption	34 cm ³		
Tempo di chiusura senza carico Closing time without load	0.14 s		
Ripetibilità Repetition accuracy	0.02 mm		
Peso Weight	940 g	980 g	900 g

Dimensioni (mm) / Dimensions (mm)

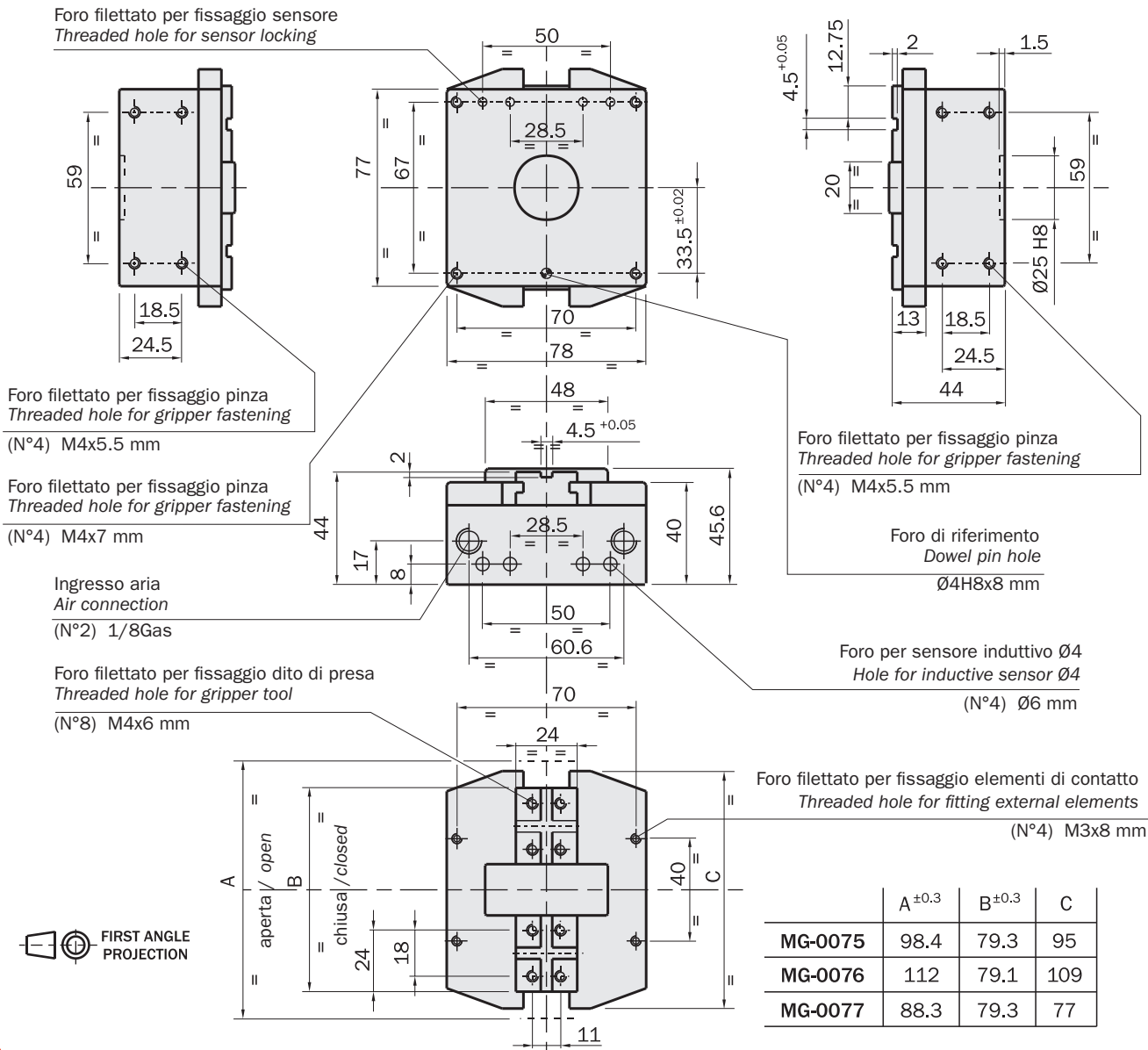

	MG-0100	MG-0101	MG-0102	MG-0103
Fluido Medium	Aria compressa filtrata, lubrificata / non lubrificata Filtered, lubricated / non lubricated compressed air			
Pressione di esercizio Operating pressure range	2÷8 bar			
Temperatura di esercizio Operating temperature range	5÷60 °C.			
Forza di serraggio per griffa a 6 bar Gripping force at 6 bar on each jaw	450 N	210 N	770 N	1200 N
Forza di serraggio totale a 6 bar Total gripping force at 6 bar	900 N	420 N	1540 N	2400 N
Corsa totale Total stroke (±0.3 mm)	23.7 mm	41 mm	11 mm	5.8 mm
Frequenza max funzionamento continuativo Maximum working frequency	2 Hz			
Consumo d'aria per ciclo Cycle air consumption	61 cm ³			
Tempo di chiusura senza carico Closing time without load	0.14 s			
Ripetibilità Repetition accuracy	0.02mm			
Peso Weight	1500 g	1600 g	1400 g	1400 g

Dimensioni (mm) / Dimensions (mm)

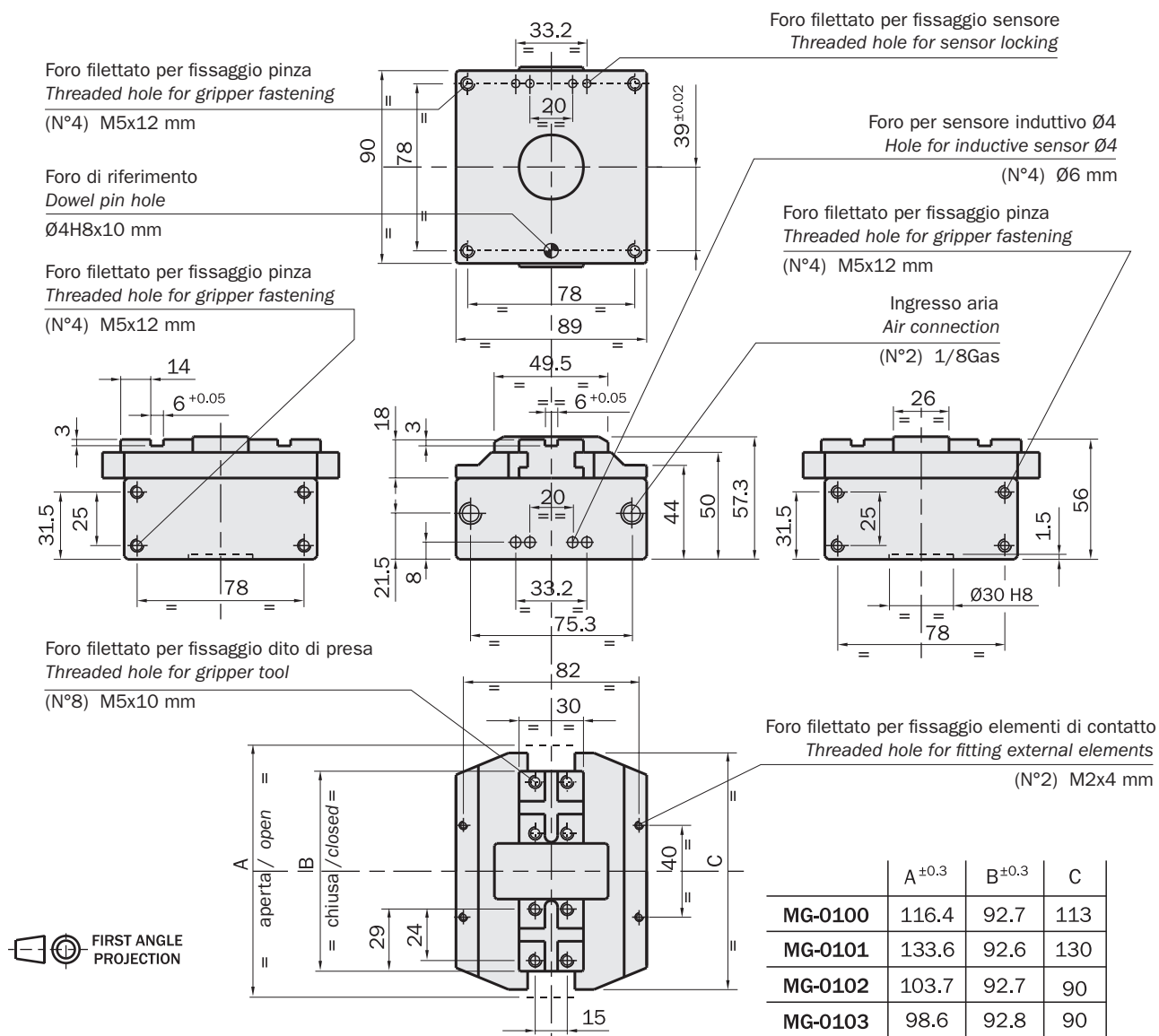

Forza di serraggio

I grafici mostrano la forza per griffa espressa dalla pinza in funzione della pressione e del braccio di leva Z.

Gripping force

The graphs show the gripping force on each jaw, as a function of the operating pressure and the gripping tool length Z.

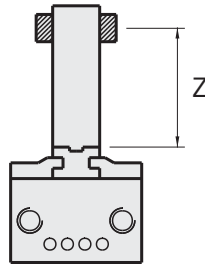

La forza indicata in questi grafici è riferita alla singola griffa. La forza totale è il doppio.

The force shown in these graphs refers to one jaw. The total force is double.

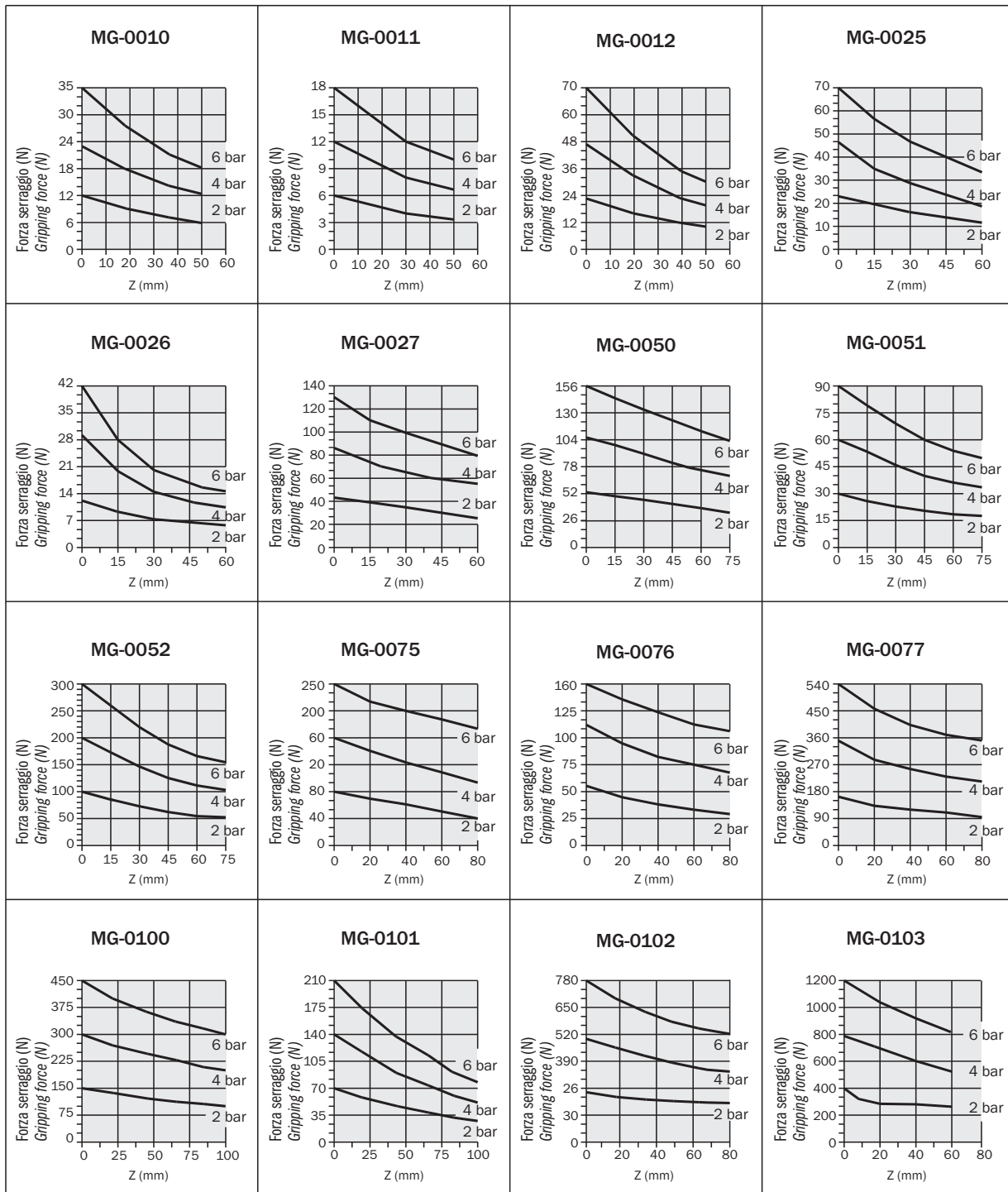

Forza di serraggio

I grafici mostrano la forza per griffa espressa dalla pinza a 6 bar in funzione del braccio Z e del disassamento del punto di presa X.

Gripping force

The graphs show the gripping force on each jaw, as a function of the gripping tool length Z and the overhanging X at 6 bar.

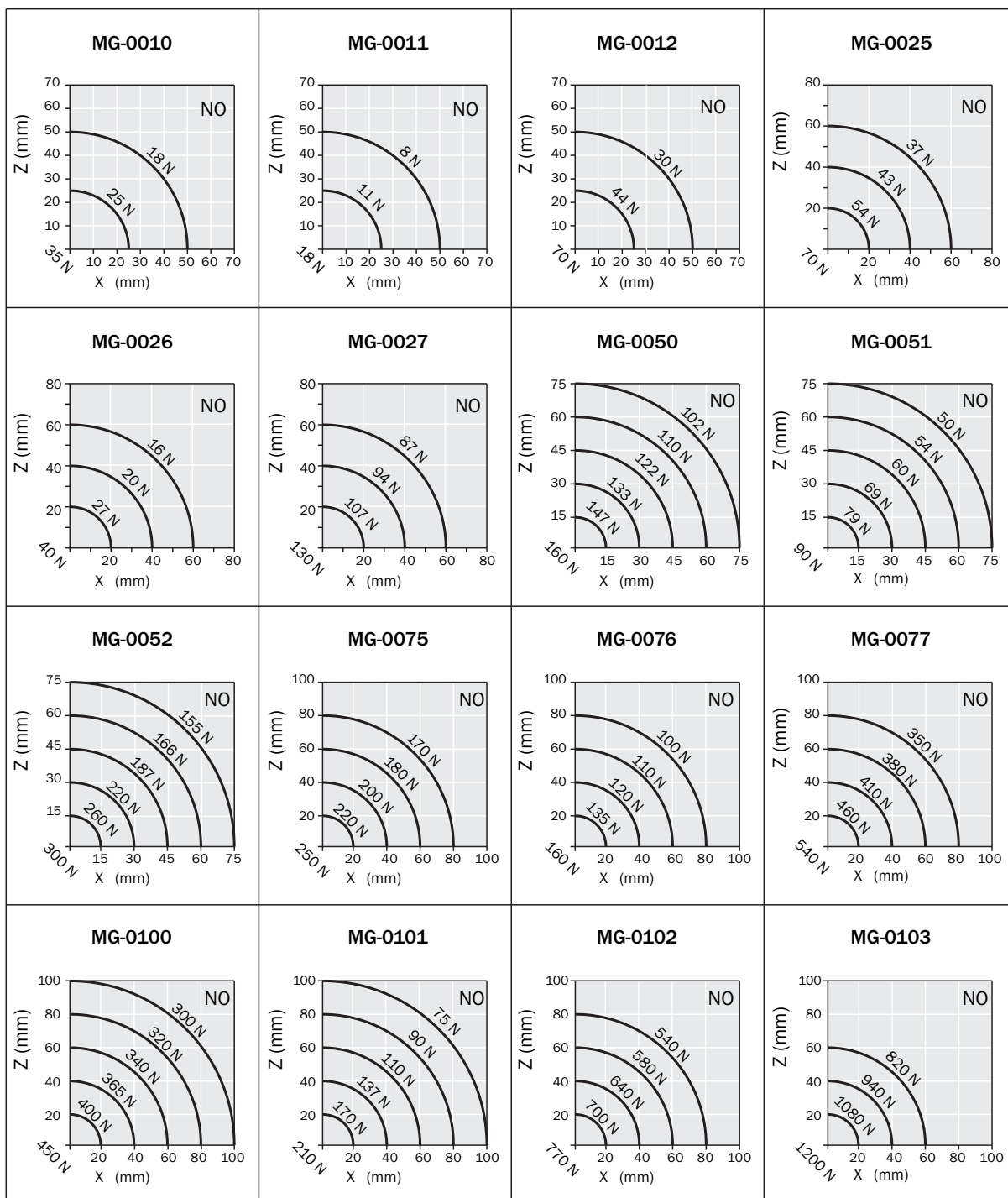
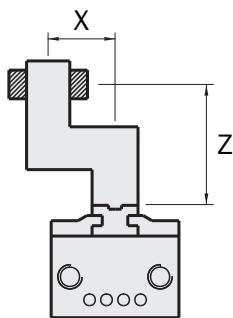

Carichi di sicurezza

Consultare la tabella per i carichi massimi ammissibili. Forze e coppie eccessive possono danneggiare la pinza e causare difficoltà di funzionamento compromettendo la sicurezza dell'operatore.

F_s , $M_x s$, $M_y s$, $M_z s$, sono i carichi massimi ammissibili in condizioni statiche, cioè con le griffe ferme.

F_d , $M_x d$, $M_y d$, $M_z d$, sono i carichi massimi ammissibili in condizioni dinamiche, cioè con le griffe in movimento.

m , è il massimo peso ammissibile su ogni dito di presa quando la pinza è utilizzata senza regolazione di velocità; per dita più pesanti si deve diminuire la velocità delle griffe agendo sui regolatori di flusso (non forniti).

Safety loads

Check the table for maximum permitted loads.

Excessive forces or torques can damage the gripper, cause functioning troubles and endanger the safety of the operator.

F_s , $M_x s$, $M_y s$, $M_z s$, are maximum permitted static loads. Static means still jaws.

F_d , $M_x d$, $M_y d$, $M_z d$, are maximum permitted dynamic loads. Dynamic means running jaws.

m , is the maximum permitted weight of each gripping tool, when the gripper works without speed adjustment.

If the weight is over the permitted value, it is necessary to decrease the speed of the jaw by using flow controllers (not supplied).

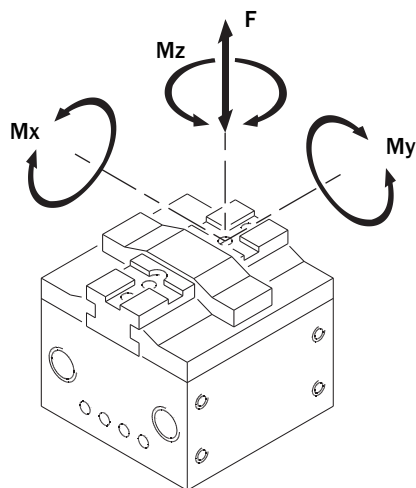

	MG-0010-11-12	MG-0025-26-27	MG-0050-51-52	MG-0075-76-77	MG-0100-101-102-103
F_s	50 N	200 N	400 N	800 N	1000 N
$M_x s$	2 Nm	6 Nm	12 Nm	28 Nm	50 Nm
$M_y s$	2 Nm	6 Nm	12 Nm	28 Nm	50 Nm
$M_z s$	2 Nm	6 Nm	12 Nm	28 Nm	50 Nm
F_d	1 N	3 N	4 N	8 N	10 N
$M_x d$	2 Ncm	6 Ncm	12 Ncm	20 Ncm	30 Ncm
$M_y d$	2 Ncm	6 Ncm	12 Ncm	20 Ncm	30 Ncm
$M_z d$	2 Ncm	6 Ncm	12 Ncm	20 Ncm	30 Ncm
m	50 g	200 g	300 g	400 g	500 g

Serraggio

La pinza è a doppio effetto e può quindi essere usata per serrare il carico sia dall'esterno che dall'interno.

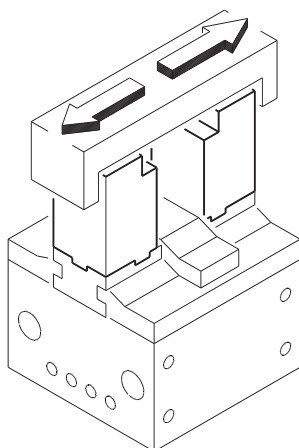

Gripping

The gripper is double-acting for either internal or external gripping applications.

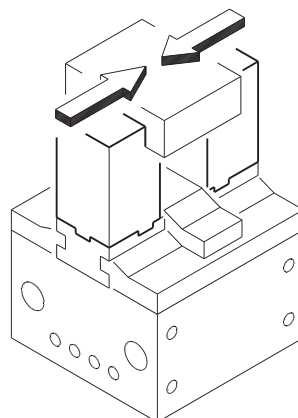

Fissaggio della pinza

La pinza può essere montata in posizione fissa oppure su parti in movimento: in questo caso va considerata la forza d'inerzia cui la pinza ed il suo carico sono sottoposti. Per fissare la pinza utilizzare i quattro fori filettati (A) sul fondo del corpo, oppure i quattro sul fianco (H). In quest'ultimo caso si deve evitare di comprimere le guide (L) con la piastra di fissaggio (Z). Per il posizionamento di precisione utilizzare il foro spina (C) e la lamatura centrale (B), nella quale va inserita, con gioco assiale, una pastiglia di centraggio (D). Lasciare lo spazio necessario per i raccordi dell'aria (E) e per il posizionamento dei sensori (F).

Gripper fastening

The gripper can be fastened to a static or moving part. When on a moving part, you must pay attention to the forces created by inertia on the gripper and its load. To fasten the gripper, use the four threaded holes (A) on the base of the gripper or the four holes on the side (H). In the latter case, be careful not to press the guides (L) against the fixing plate (Z). The gripper must be aligned using the dowel pin hole (C) and the centering spot face (B), in which the centering disc (D) must be fitted with axial backlash. Allow room to mount the air fittings (E) and the sensors (F).

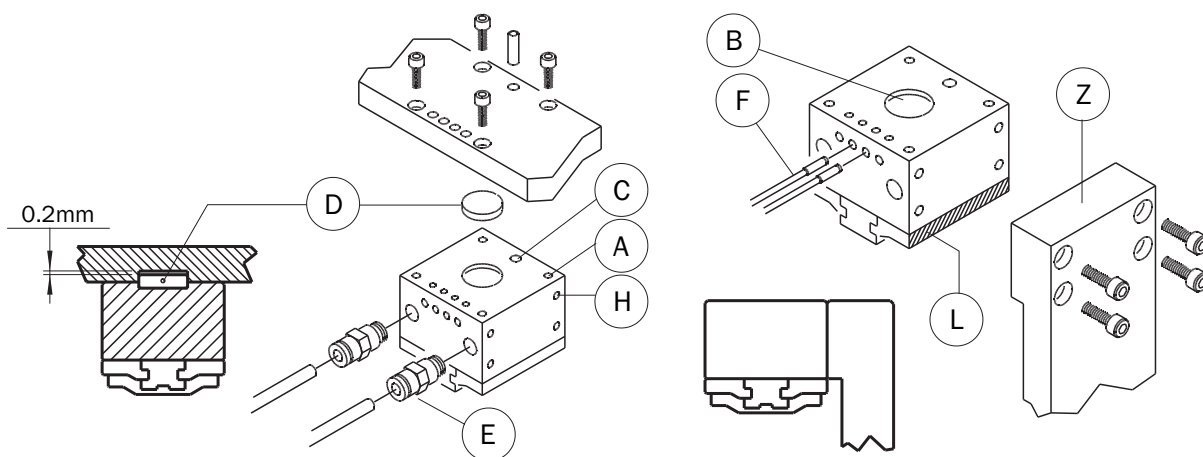

	MG-0010-11-12	MG-0025-26-27	MG-0050-51-52	MG-0075-76-77	MG-0100-101-102-103
A	M3x4 mm	M3x6 mm	M4x8 mm	M4x7 mm	M5x12 mm
B	Ø10H8x0.8 mm	Ø15H8x1.6 mm	Ø20H8x1.5 mm	Ø25H8x1.5 mm	Ø30H8x1.5 mm
C	Ø2H8x4 mm	Ø3H8x5 mm	Ø4H8x8 mm	Ø4H8x8 mm	Ø4H8x10 mm
E	M5	M5	G1/8	G1/8	G1/8
F	Ø4 mm	Ø4 mm	Ø4 mm	Ø4 mm	Ø4 mm
H	-	M3x4 mm	M4x8 mm	M4x5.5 mm	M5x12 mm

Fissaggio delle estremità di presa

Costruire le dita di presa il più possibile corte e leggere. Per il centraggio sulle griffe utilizzare le scanalature calibrate (J) e per il fissaggio i fori filettati (K).

Gripping tool fastening

The gripping tools must be as short and light as possible. They must be mounted using the threaded holes (K) and the key slots (J) on the jaws.

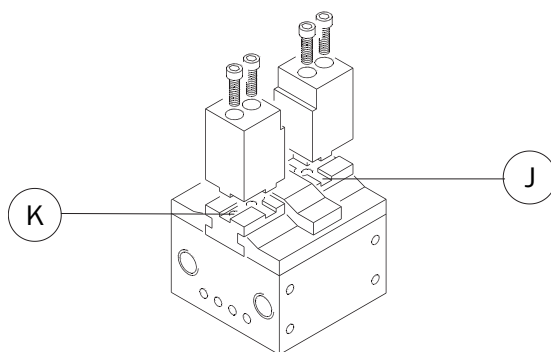

	MG-0010-11-12	MG-0025-26-27	MG-0050-51-52	MG-0075-76-77	MG-0100-101-102-103
J	3.5 ^{+0.05} x1 mm	4.5 ^{+0.05} x1 mm	5 ^{+0.05} x1.5 mm	4.5 ^{+0.05} x2 mm	6 ^{+0.05} x3 mm
K	M3x5 mm	M3x5 mm	M4x5 mm	M4x6 mm	M5x10 mm

Sensori

Il rilevamento della posizione di lavoro è affidato a uno o più sensori induttivi (opzionali) di diametro 4mm, che rilevano la posizione del cursore interno.

Per il montaggio:

- 1- Togliere i tappi di protezione solo dalle posizioni che si vogliono utilizzare.
- 2- Calzare il sensore utilizzando, dove previsto, l'apposita guaina di riduzione (A), inclusa nella confezione insieme con le viti senza testa (B).
- 3- Inserire il sensore a fondo nel foro, quindi bloccarlo avvitando la vite senza testa, dal fondo del corpo.
Attenzione a non danneggiare il sensore serrando eccessivamente la vite senza testa.

Sensors

The operating position can be checked by inductive sensors Ø4mm (optional), that detect the inner cursor.

For mounting:

- 1- Remove the plastic plugs only from the sensor holes which have to be used.
- 2- For sensor installation use the grub screws (B) and, where necessary, the plastic reduction sleeve (A); both are included in the gripper packaging.
- 3- The sensor must be completely inserted into its hole and locked by the grub screw. Be careful not to damage it by overtightening.

Codici di ordinazione dei sensori induttivi:

SI4M225-G	NPN	Cavo 2.5m / 2.5m cable
SI4N225-G	PNP	Cavo 2.5m / 2.5m cable

Ordering codes of the inductive sensors:

Usare i diagrammi seguenti come guida per il campo di intervento dei sensori.
Use the following diagrams as guides for correct sensor positioning.

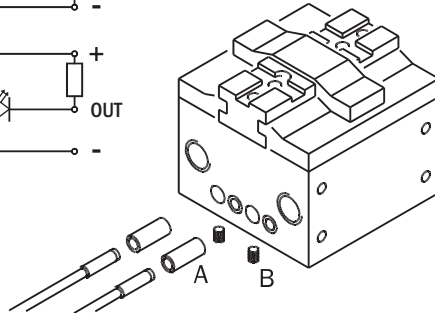
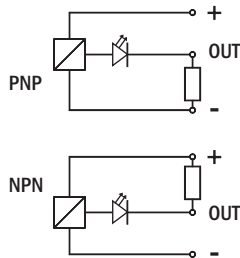

MG-0010/11/12

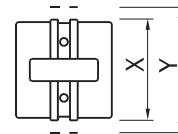
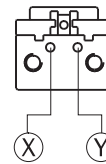

	MG-0010	MG-0011	MG-0012
X	30.6 +3	31 +6	30.6 +1.9
Y	35.6 -3.4	39.8 -5.8	33 -1.9

MG-0025/26/27

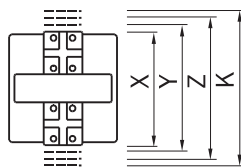
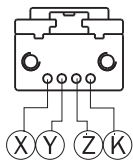

	MG-0025	MG-0026	MG-0027
X	43.4 +2.5	43 +3.3	43.2 +1.4
Y	46.9 +4.1	49.3 +6.2	45 +2.1
Z	48.1 -3.9	51.8 -7.3	47.3 -1.3
K	51.6 -2.4	57.8 -4.3	45.5 -1.9

MG-0050/51/52

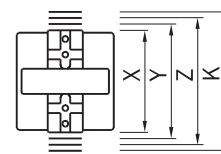
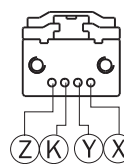

	MG-0050	MG-0051	MG-0052
X	50.5 +3	50.5 +4.5	50.5 +1.5
Y	50.5 +10.5	50.5 +17.5	50.5 +4.5
Z	62.5 -3.5	70 -4.5	56 -1.5
K	62.5 -11	70 -17.5	56 -4.5

MG-0075/76/77

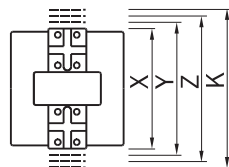
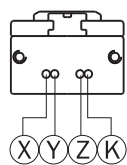

	MG-0075	MG-0076	MG-0077
X	79.5 +4.9	79.2 +8.4	79.6 +2.4
Y	87 +9.7	91.6 +17.6	83.2 +4.5
Z	91 -10	99.3 -17.7	88.5 -2.1
K	98.2 -4.7	112.1 -8.6	85 -4.5

MG-0100/101/102/103

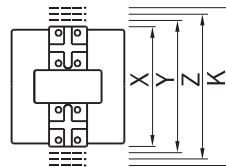
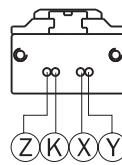

	MG-0100	MG-0101	MG-0102	MG-0103
X	92.5 +2	92.8 +5.2	92.8 +1.5	92.9 +0.7
Y	97.5 +5	100 +11	94.5 +3	94.3 +1.1
Z	106.5 -5	126 -11	102 -3	97.5 -1.2
K	114 -2.5	133.5 -5	103.8 -1.5	98.6 -0.5

Avvertenze

Evitare il contatto con sostanze corrosive, spruzzi di saldatura, polveri abrasive, che potrebbero danneggiare la funzionalità della pinza.

Per nessun motivo, persone od oggetti estranei devono entrare nel raggio d'azione della pinza.

La pinza non deve essere messa in servizio prima che la macchina di cui fa parte sia stata dichiarata conforme alle disposizioni di sicurezza vigenti.

Cautions

Avoid the gripper coming into contact with the following media: coolants which cause corrosion, grinding dust or glowing sparks. Make sure that nobody can place his/her hand between the gripping tools and there are no objects in the path of the gripper. The gripper must not run before the whole machine, on which it is mounted, complies with the laws or safety norms of your country.

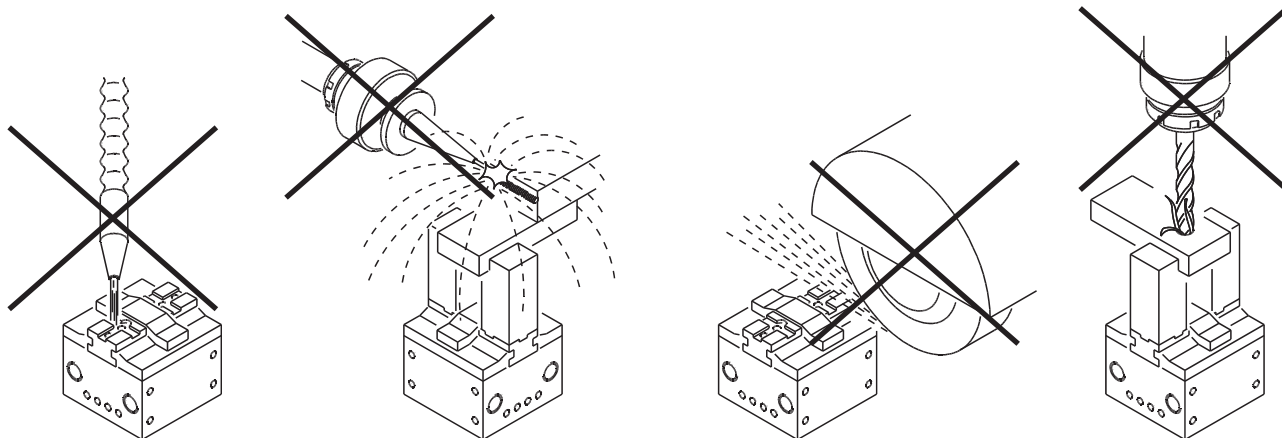

Manutenzione

La pinza va ingrassata ogni 40 milioni di cicli con:

- BERULUB FG-H 2 EP
(Lubrificante NSF H1 Registrazione No. 140486).

Il gioco delle griffe è indicato qui sotto.

Maintenance

Grease the gripper after 40 million cycles with:

- BERULUB FG-H 2 EP
(Lubricant NSF H1 Registration No. 140486).

The figure below shows the jaw backlash.

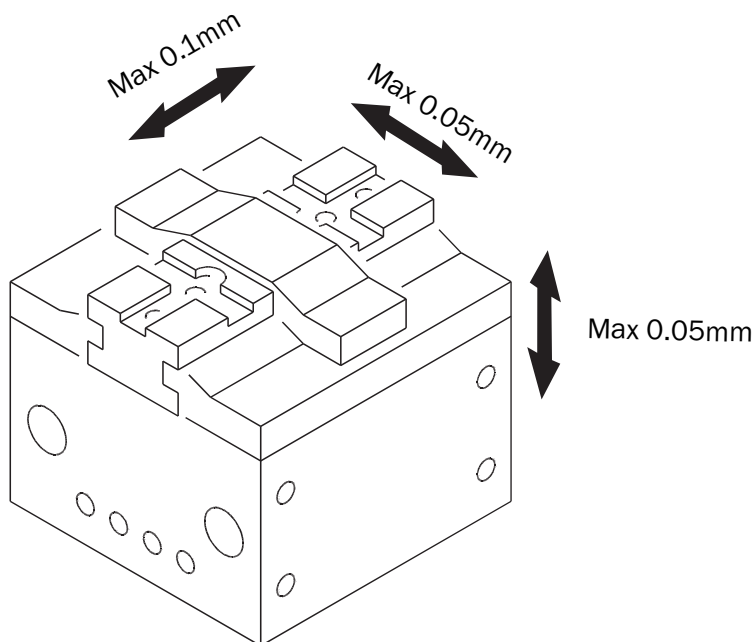

Elenco delle parti / Part list

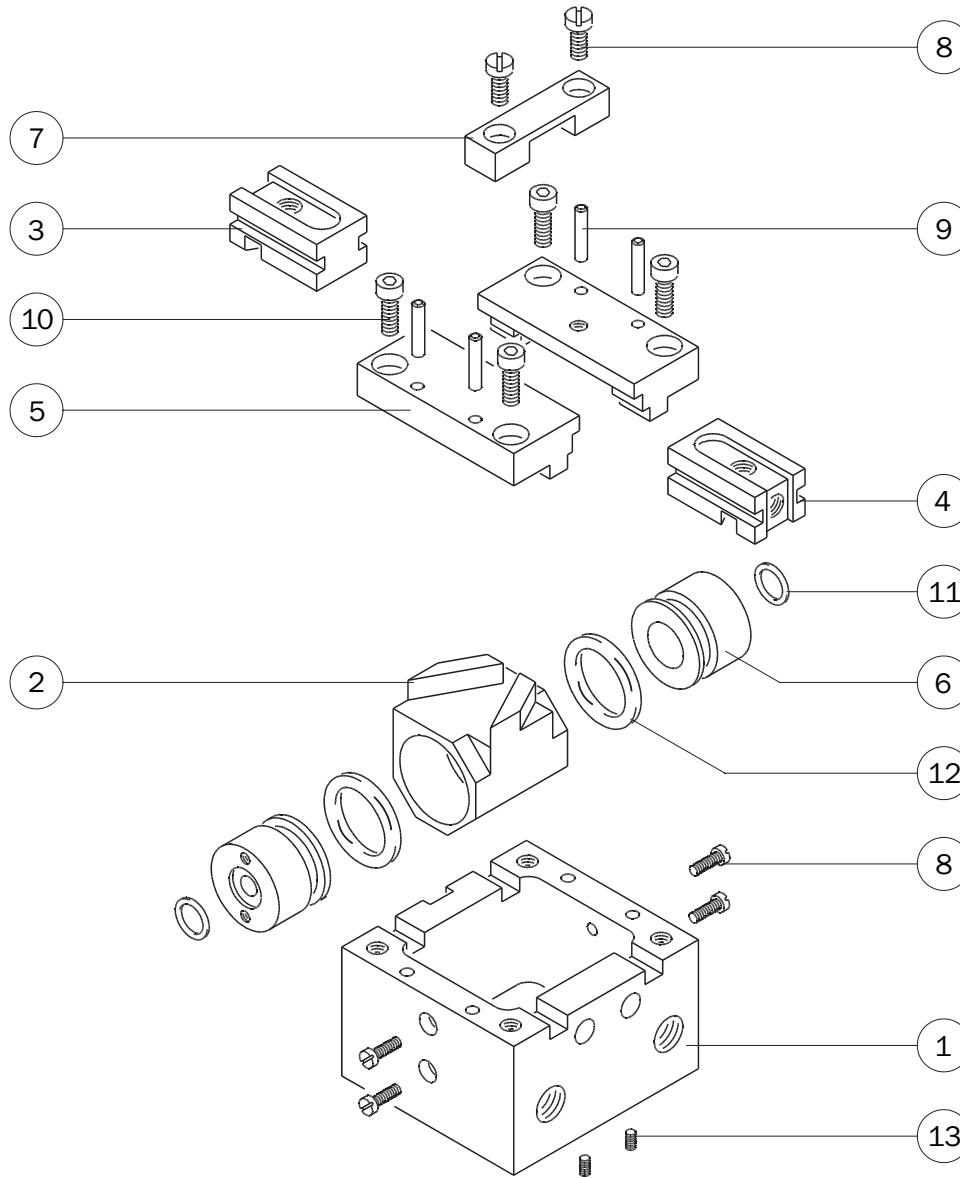

		MG-0010	MG-0011	MG-0012		
1	Corpo pinza		MG-0010-1		Gripper housing	1
2	Cursore	MG-0010-2	MG-0011-1	MG-0012-1	Slider	2
3	Griffa destra	MG-0010-4D	MG-0011-2D	MG-0012-2D	Right jaw	3
4	Griffa sinistra	MG-0010-4S	MG-0011-2S	MG-0012-2S	Left jaw	4
5	Guida	MG-0010-3	MG-0011-3	MG-0010-3	Guidance block	5
6	Pistone		MG-0010-5		Piston	6
7	Protezione	MG-0010-6	MG-0011-6	MG-0012-6	Cover	7
8	Vite		VITE-056 (M2x5 mm DIN84A INOX A2)		Screw	8
9	Spina di riferimento		SPINA-020 (Ø2x8 mm DIN6325)		Dowel pin	9
10	Vite		VITE-097 (M3x5 mm DIN912 INOX A2)		Screw	10
11	O-RING		GUAR-021 (Ø1x5)		O-RING	11
12	O-RING		GUAR-020 (Ø1.5x8.5)		O-RING	12
13	Vite senza testa		VITE-018 (M3x4 mm DIN913 INOX A2)		Grub screw	13

Elenco delle parti / Part list

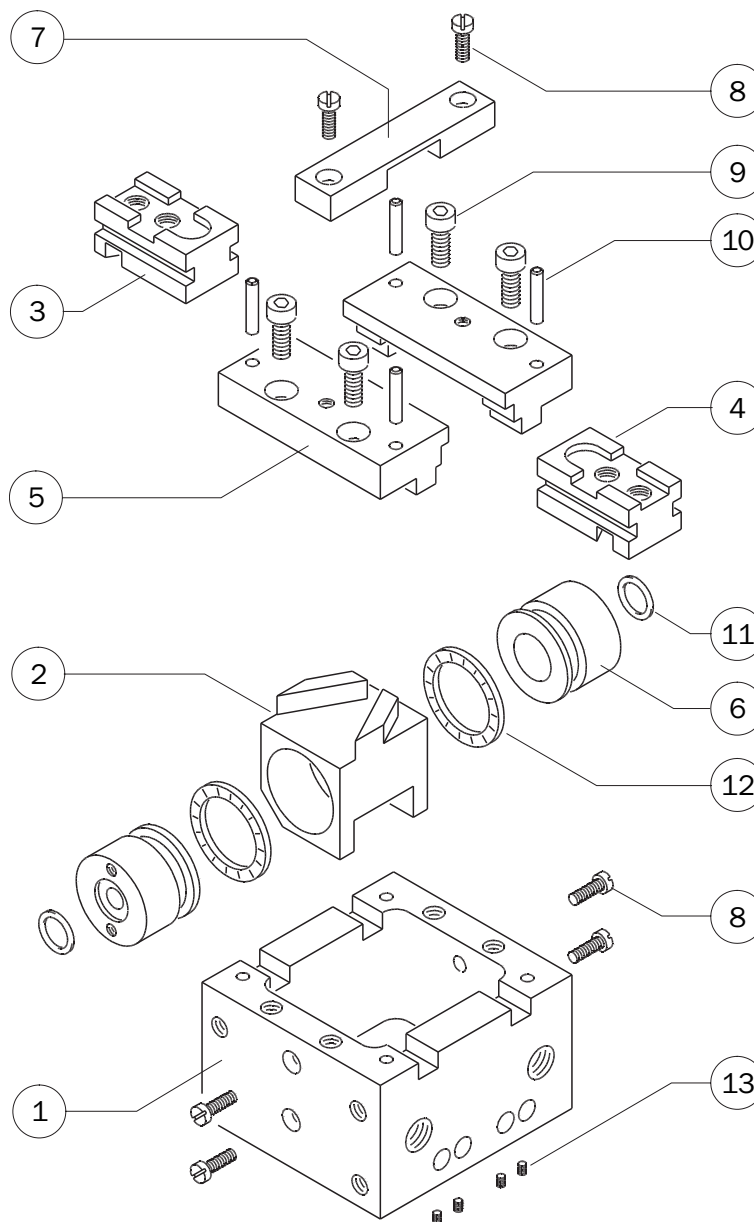

		MG-0025	MG-0026	MG-0027		
1	Corpo pinza		MG-0025-1		Gripper housing	1
2	Cursore	MG-0025-2	MG-0026-1	MG-0027-1	Slider	2
3	Griffa destra	MG-0025-4D	MG-0026-2D	MG-0027-2D	Right jaw	3
4	Griffa sinistra	MG-0025-4S	MG-0026-2S	MG-0027-2S	Left jaw	4
5	Guida	MG-0025-3	MG-0026-3	MG-0027-3	Guidance block	5
6	Pistone		MG-0025-6		Piston	6
7	Protezione	MG-0025-5	MG-0026-5	MG-0027-5	Cover	7
8	Vite		VITE-056 (M2x5 mm DIN84A INOX A2)		Screw	8
9	Vite		VITE-017 (M3x6 mm DIN912 INOX A2)		Screw	9
10	Spina di riferimento		SPINA-020 (Ø2x8 mm DIN6325)		Dowel pin	10
11	O-RING		GUAR-021 (Ø1x5)		O-RING	11
12	Guarnizione dinamica		GUAR-002P (16x9x2.5)		Dynamic gasket	12
13	Vite senza testa		VITE-018 (M3x4 mm DIN913 INOX A2)		Grub screw	13

09/2017

Elenco delle parti / Part list

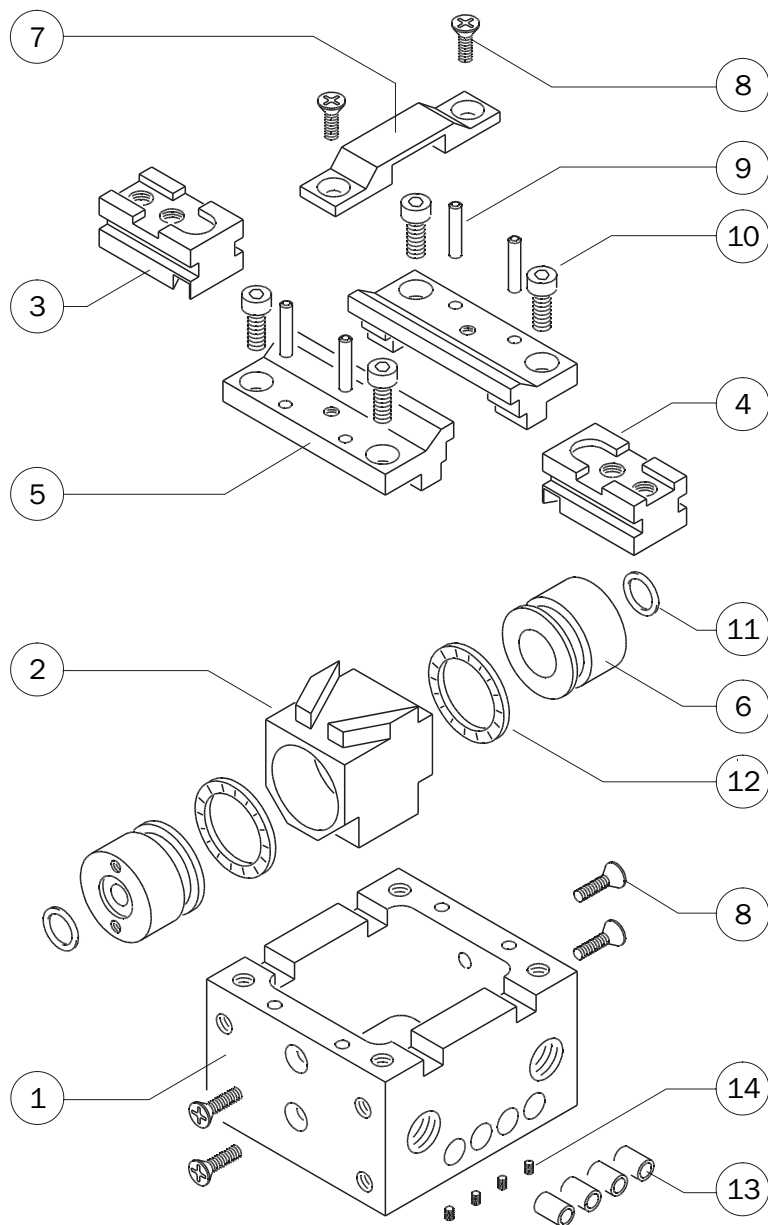

		MG-0050	MG-0051	MG-0052		
1	Corpo pinza		MG-0050-1		Gripper housing	1
2	Cursore	MG-0050-2	MG-0051-1	MG-0052-1	Slider	2
3	Griffa destra	MG-0050-4D	MG-0051-2D	MG-0052-2D	Right jaw	3
4	Griffa sinistra	MG-0050-4S	MG-0051-2S	MG-0052-2S	Left jaw	4
5	Guida	MG-0050-3	MG-0051-3	MG-0052-3	Guidance block	5
6	Pistone		MG-0050-6		Piston	6
7	Protezione	MG-0050-5	MG-0051-5	MG-0052-5	Cover	7
8	Vite		VITE-012 (M3x10 mm DIN965A INOX A2)		Screw	8
9	Spina di riferimento		SPINA-022 (Ø3x12 mm DIN6325)		Dowel pin	9
10	Vite		VITE-009 (M4x8 mm DIN912 INOX A2)		Screw	10
11	O-RING		GUAR-022 (Ø1.5x11)		O-RING	11
12	Guarnizione dinamica		GUAR-003M (25x18x2.4)		Dynamic gasket	12
13	Riduzione per sensore	MG-0050-7	MG-0051-7	MG-0052-7	Plastic adapter	13
14	Vite senza testa		VITE-018 (M3x4 mm DIN913 INOX A2)		Grub screw	14

Elenco delle parti / Part list

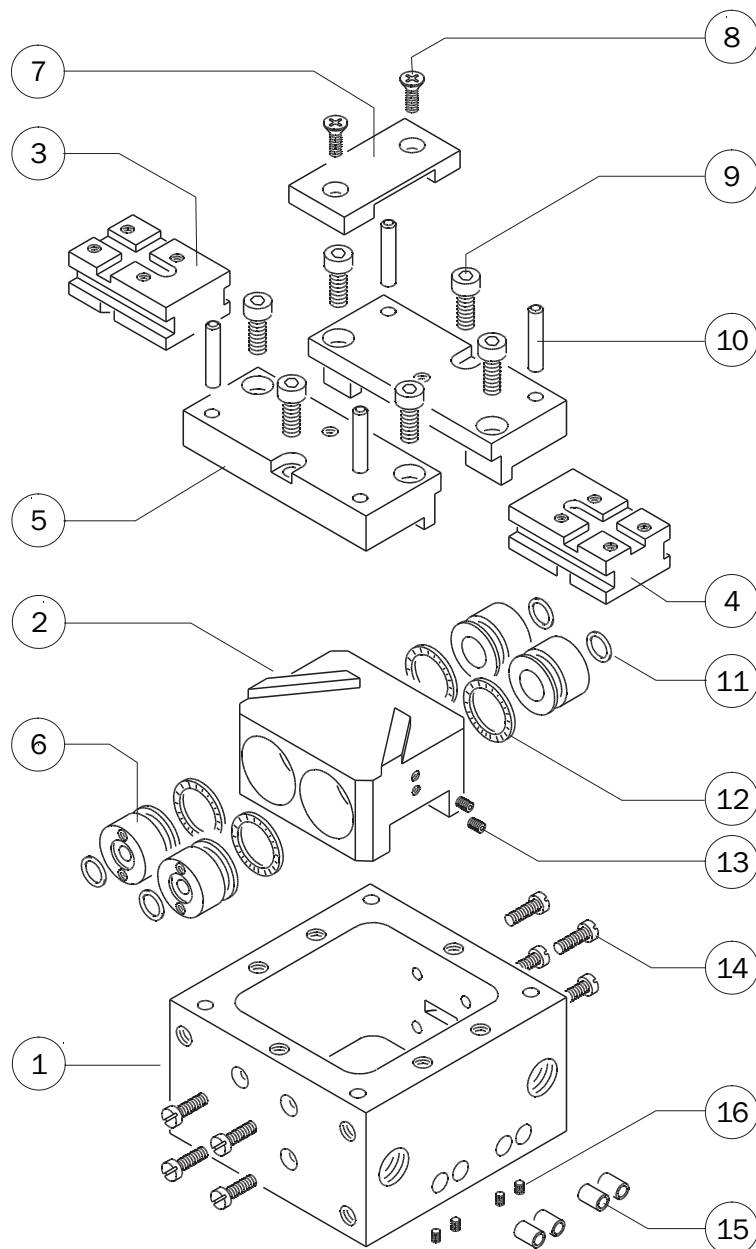

	MG-0075	MG-0076	MG-0077			
1	Corpo pinza		MG-0075-1	Gripper housing	1	
2	Cursore	MG-0076-1	MG-0077-1	Slider	2	
3	Griffa destra	MG-0076-2D	MG-0077-2D	Right jaw	3	
4	Griffa sinistra	MG-0076-2S	MG-0077-2S	Left jaw	4	
5	Guida	MG-0076-3	MG-0077-3	Guidance block	5	
6	Pistone	MG-0075-6		Piston	6	
7	Protezione	MG-0076-5	MG-0077-5	Cover	7	
8	Vite	VITE-012 (M3x10 mm DIN965A INOX A2)		Screw	8	
9	Vite	VITE-020 (M4x10 mm DIN912 INOX A2)		Screw	9	
10	Spina di riferimento	SPINA-022 (Ø3x12 mm DIN6325)		Dowel pin	10	
11	O-RING	GUAR-037 (Ø1.78x11.11)		O-RING	11	
12	Guarnizione dinamica	GUAR-003M (25x18x2.4)		Dynamic gasket	12	
13	Vite senza testa	VITE-043 (M4x8 mm DIN913 INOX A2)		Grub screw	13	
14	Vite	VITE-056 (M2x5 mm DIN84A INOX A2)		Screw	14	
15	Riduzione per sensore	MG-0050-7	MG-0051-7	MG-0052-7	Plastic adapter	15
16	Vite senza testa	VITE-018 (M3x4 mm DIN913 INOX A2)		Grub screw	16	

Elenco delle parti / Part list

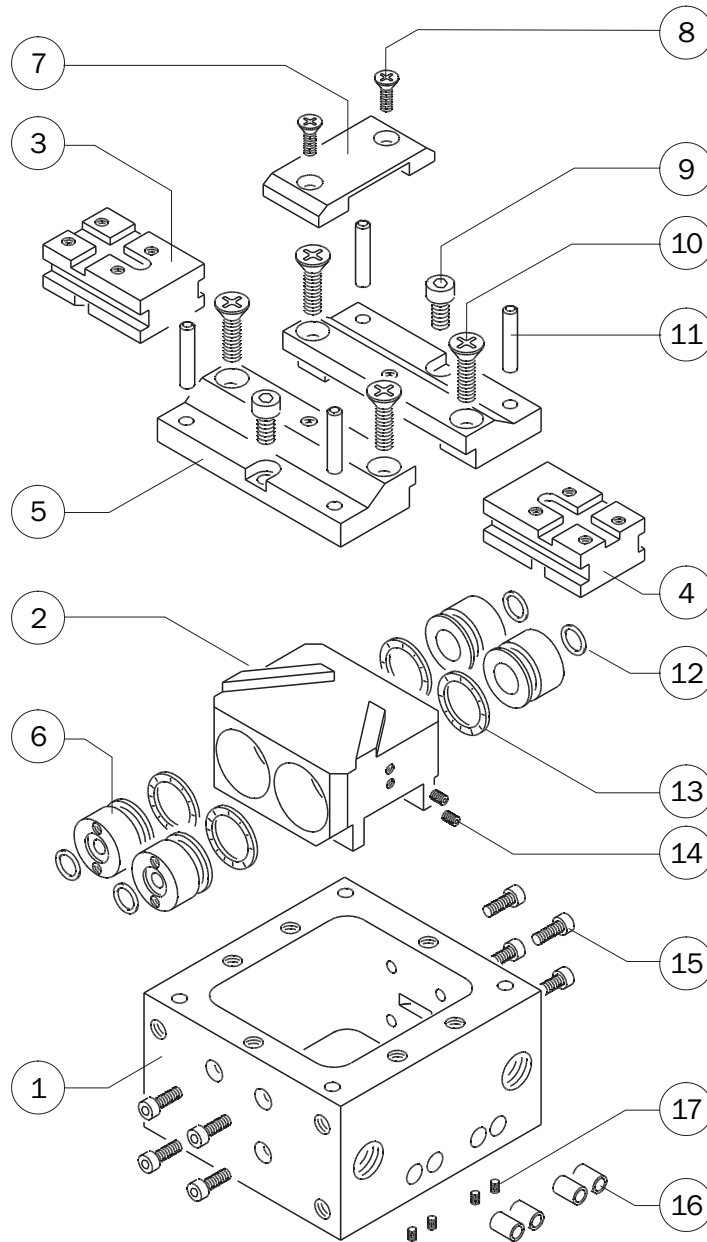

	MG-0100	MG-0101	MG-0102	MG-0103			
1	Corpo pinza	MG-0100-1				Gripper housing	1
2	Cursore	MG-0100-2	MG-0101-2	MG-0102-2	MG-0103-2	Slider	2
3	Griffa destra	MG-0100-3D	MG-0101-3D	MG-0102-3D	MG-0103-3D	Right jaw	3
4	Griffa sinistra	MG-0100-3S	MG-0101-3S	MG-0102-3S	MG-0103-3S	Left jaw	4
5	Guida	MG-0100-4	MG-0101-7	MG-0102-7	MG-0102-7	Guidance block	5
6	Pistone	MG-0100-5				Piston	6
7	Protezione	MG-0100-6	MG-0101-6	MG-0102-6	MG-0103-6	Cover	7
8	Vite	VITE-022 (M3x12 mm DIN965A INOX A2)				Screw	8
9	Vite	VITE-020 (M4x10 mm DIN912 INOX A2)				Screw	9
10	Vite	VITE-015 (M5x16 mm DIN912 INOX A2)				Screw	10
11	Spina di riferimento	SPINA-019 (Ø4x14 mm DIN6325)				Dowel pin	11
12	O-RING	Ø1.78x15.60 (GUAR-023)				O-RING	12
13	Guarnizione dinamica	GUAR-024P (30x21x3)				Dynamic gasket	13
14	Vite senza testa	VITE-043 (M4x8 mm DIN913 INOX A2)				Grub screw	14
15	Vite	VITE-016 (M3x10 mm DIN912 INOX A2)				Screw	15
16	Riduzione per sensore	MG-0050-7	MG-0051-7	MG-0052-7	MG-0103-7	Plastic adapter	16
17	Vite senza testa	VITE-018 (M3x4 mm DIN913 INOX A2)				Grub screw	17

Connessione pneumatica

La pinza si alimenta con aria compressa dai fori laterali (P e R) montandovi i raccordi dell'aria ed i relativi tubi (non forniti).

La pinza è azionata con aria compressa filtrata (5÷40 µm) non necessariamente lubrificata.

La scelta iniziale, lubrificata o non lubrificata, deve essere mantenuta per tutta la vita della pinza.

L'impianto pneumatico deve essere pressurizzato gradualmente, per evitare movimenti incontrollati.

Compressed air feeding

The compressed air feeding can be accomplished on the lateral air ports (P and R) with fittings and hoses (not supplied).

The compressed air, must be filtered from 5 to 40 µm. Maintain the medium selected at the start, lubricated or not, for the complete service life of the gripper.

The pneumatic circuit must be pressurized progressively, to avoid uncontrolled movements.

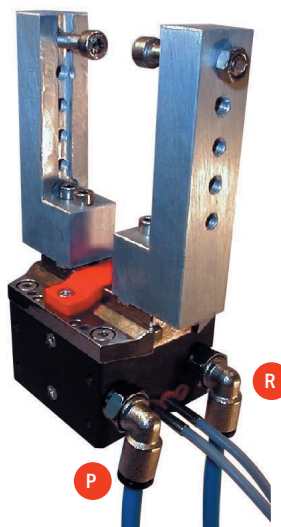

Circuito pneumatico

Possibili inconvenienti sul circuito di alimentazione dell'aria compressa:

- 1- Oscillazioni di pressione.
- 2- Riempimento pinza vuota all'avvio.
- 3- Improvvisa mancanza di pressione.
- 4- Velocità di azionamento eccessiva.

Accorgimenti per risolvere i problemi:

- 1- Serbatoio esterno (A).
- 2- Valvola di avviamento progressivo (B).
- 3- Valvole di sicurezza (C).
- 4- Regolatori di flusso (D).

Pneumatic circuit

Possible problems on a compressed air circuit:

- 1- Pressure variation.
- 2- Pressurizing with empty cylinders.
- 3- Sudden pressure black-out.
- 4- Excessive speed of the jaws.

Possible solutions:

- 1- Compressed air storage (A).
- 2- Start-up valve (B).
- 3- Safety valve (C).
- 4- Flow controller (D).

