

AF

Valvole ad otturatore per aria compressa G1/8 ÷ G1 1/2

- Ampia gamma: G1/8 - G1/4 - G3/8 - G1/2 - G3/4 - G1 - G1 1/2
- Sistema ad otturatore originale Univer riconosciuto negli anni dal mercato
- Adatte ad applicazioni dove necessitano portate e numero di cicli elevati
- Versione G1 - 2/2 per soffiaggio filtri a manica



CARATTERISTICHE TECNICHE

Temperatura ambiente	+50 °C Max						
Temperatura fluido	-5 ÷ +60 °C						
Fluido	aria filtrata 50 µm lubrificata o non						
Sistema di commutazione	otturatore						
Vie/Posizioni	2/2 NC (su richiesta), 3/2 NC, 3/2 NO, 3/2 NC-NO						
Pressione	max 10 bar						
Comando	pneumatico, elettropneumatico indiretto						
Ritorno	molla pneumomeccanica						
Conessioni	G 1/8	G 1/4	G 3/8	G 1/2	G 3/4	G 1	G 1 1/2
Diametro nominale (mm)	5,5	8	10	15	19	25	39
Portata nominale (NI/min)	580	1100	1500	5400	6500	13500	35000

CARATTERISTICHE COSTRUTTIVE

Corpo valvola	G1/8 ÷ G1 = zama G1 1/2 = alluminio
Guarnizioni	gomma nitrilica, poliuretano
Operatori	G1/8 ÷ G1 = zama G1 1/2 = alluminio
Spola	G1/8 ÷ G3/8 = alluminio G1/2 ÷ G1 1/2 = acciaio + plastica

CARATTERISTICHE ELETTRICHE

	G1/8 G1/4	G1/4 ÷ G1 1/2
Elettropilota	U1	U2
Bobina	DA	DB
Assorbimento	3,5 W (DC) - 5 VA (AC)	11 W (DC) - 10 VA (AC)
Connettore	AM-5110	AM-5111
Tensione	12 V DC - 24 V DC - 24 V AC - 110 V AC - 230 V AC	
Comando manuale	a vite 2 posizioni	

Elettrovalvole G1/8 - G1/4 - G3/8

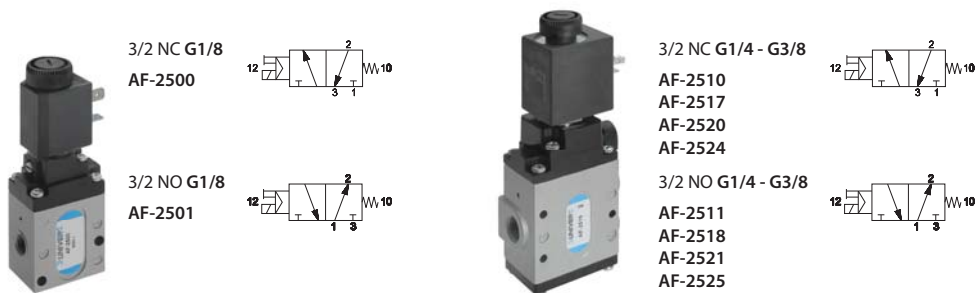

	Attacco	Comando	Ritorno	Portata (Nl/min)	Ø mm	Tempo (ms)		Pressione bar		Peso Kg	Bobina	Codice
						Ecc.	Dis.	min.	max.			
3/2 NC	G1/8	elettrico amplificato	molla pneumomeccanica	580	5,5	15	20	1,5	10	0,25	U1	AF-2500
	G1/4	elettrico amplificato	molla pneumomeccanica	1100	8	20	23	1,6	10	0,58	U1	AF-2510
	G1/4	elettrico amplificato	molla pneumomeccanica	1100	8	20	23	1,6	10	0,70	U2	AF-2517
	G3/8	elettrico amplificato	molla pneumomeccanica	1500	10	20	23	1,6	10	0,56	U1	AF-2520
	G3/8	elettrico amplificato	molla pneumomeccanica	1500	10	20	23	1,6	10	0,70	U2	AF-2524
3/2 NO	G1/8	elettrico amplificato	molla pneumomeccanica	580	5,5	15	20	1,5	10	0,25	U1	AF-2501
	G1/4	elettrico amplificato	molla pneumomeccanica	1100	8	15	20	1,6	10	0,58	U1	AF-2511
	G1/4	elettrico amplificato	molla pneumomeccanica	1100	8	15	20	1,6	10	0,70	U2	AF-2518
	G3/8	elettrico amplificato	molla pneumomeccanica	1500	10	15	20	1,6	10	0,56	U1	AF-2521
	G3/8	elettrico amplificato	molla pneumomeccanica	1500	10	15	20	1,6	10	0,70	U2	AF-2525

G1/8

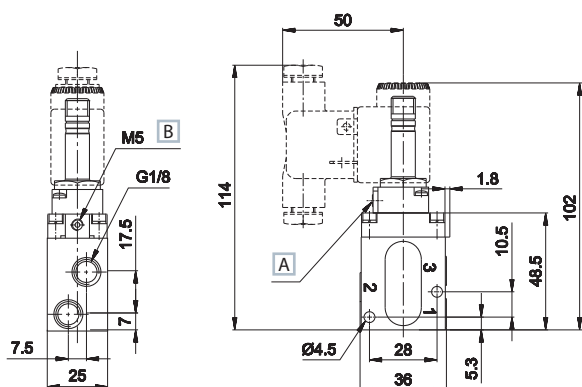

- 1 = Alimentazione
- 2 = Utilizzo
- 3 = Scarico

- A Comando manuale
- B Servoalimentazione esterna del pilota

G1/4 - G3/8

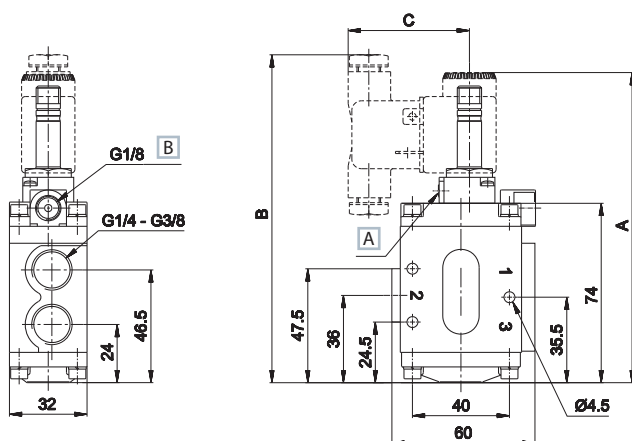

- 1 = Alimentazione
- 2 = Utilizzo
- 3 = Scarico

- A Comando manuale
- B Servoalimentazione esterna del pilota

	A	B	C
U1	129	136	50
U2	140,5	150	51,5

Su richiesta:
 - servoalimentazione esterna del pilota
 - G1/4 - G3/8 U2 senza comando manuale
 Le elettrovalvole sono fornite senza bobina, connettore e ghiera di bloccaggio

Elettrovalvole G1/2 - G3/4 - G1 - G1 1/2



3/2 NC G1/2 - G3/4 - G1
 AF-2530
 AF-2540
 AF-2545

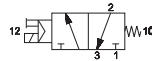

3/2 NC G1 1/2
 AF-2565

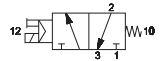

3/2 NO G1/2 - G3/4 - G1
 AF-2531
 AF-2541
 AF-2546

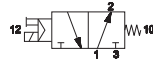

3/2 NO G1 1/2
 AF-2561

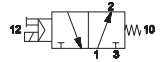

	Attacco	Comando	Ritorno	Portata (Nl/min)	Ø mm	Tempo (ms)		Pressione bar		Peso Kg	Bobina	Codice
						Ecc.	Dis.	min.	max.			
3/2 NC	G1/2	elettrico amplificato	molla pneumomeccanica	5400	15	17	27	2	10	1,19	U2	AF-2530
	G3/4	elettrico amplificato	molla pneumomeccanica	6500	19	17	27	2	10	1,13	U2	AF-2540
	G1	elettrico amplificato	molla pneumomeccanica	13500	25	20	32	2,2	10	1,62	U2	AF-2545
	G1 1/2	elettrico amplificato	molla pneumomeccanica	35000	39	47	22	2,5	10	2,27	U2	AF-2565
3/2 NO	G1/2	elettrico amplificato	molla pneumomeccanica	5400	15	30	22	3	10	1,19	U2	AF-2531
	G3/4	elettrico amplificato	molla pneumomeccanica	6500	19	30	22	3	10	1,13	U2	AF-2541
	G1	elettrico amplificato	molla pneumomeccanica	13500	25	28	23	3	10	1,62	U2	AF-2546
	G1 1/2	elettrico amplificato	molla pneumomeccanica	35000	39	55	20	3	10	2,27	U2	AF-2561

G1/2 - G3/4 - G1

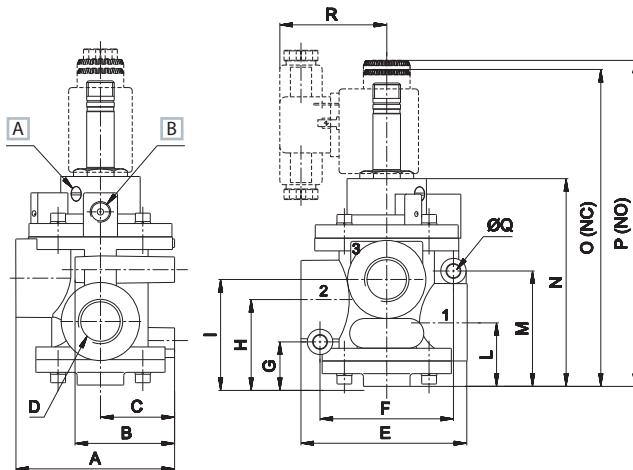

- 1 = Alimentazione
- 2 = Utilizzo
- 3 = Scarico

- A Comando manuale
- B Servoalimentazione esterna del pilota

	A	B	C	D	E	F	G	H	I	L	M	N	O	P	Q	R
G1/2	75	47	35	G1/2	78,5	63	21	41	50,5	30	54,5	100	150	154	6,4	50,5
G3/4	75	47	35	G3/4	78,5	63	21	41	50,5	30	54,5	100	150	154	6,4	50,5
G1	89	55	40	G1	101	76	25,5	51	64	38	62,5	115	167	175	8,4	50

G1 1/2

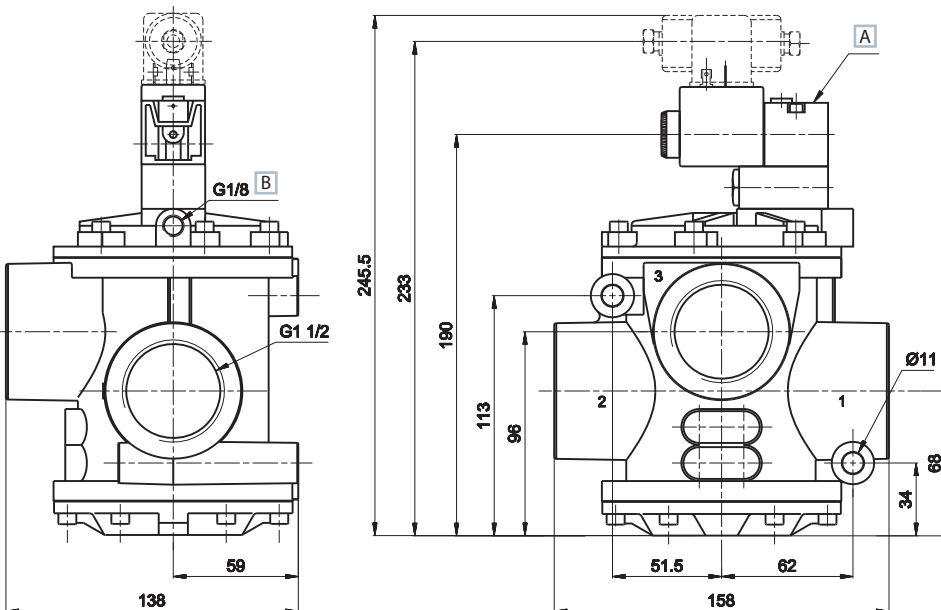

- 1 = Alimentazione
- 2 = Utilizzo
- 3 = Scarico

- A Comando manuale
- B Servoalimentazione esterna del pilota

Le elettrovalvole sono fornite senza bobina, connettore e ghiera di bloccaggio

Servovalvole G1/8 - G1/4 - G3/8



3/2 NC G1/8
AF-2600

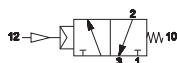

3/2 NO G1/8
AF-2700

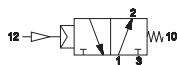

3/2 NC G1/4 - G3/8
AF-2601
AF-2606

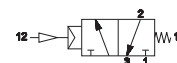

3/2 NO G1/4 - G3/8
AF-2701
AF-2706

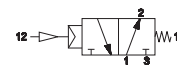

	Attacco	Comando	Ritorno	Portata (Nl/min)	Ø (mm)	Tempo (ms)		Pressione bar		Peso (Kg)	Codice
						Ecc.	Dis.	alimen.	comando		
3/2 NC	G1/8	pneumatico amplificato	molla pneumomeccanica	580	5,5	5	8	6	3,5	0,21	AF-2600
	G1/4	pneumatico amplificato	molla pneumomeccanica	1100	8	5	7	6	4	0,54	AF-2601
	G3/8	pneumatico amplificato	molla pneumomeccanica	1500	10	5	7	6	4	0,52	AF-2606
3/2 NO	G1/8	pneumatico amplificato	molla pneumomeccanica	580	5,5	5	8	6	3,5	0,21	AF-2700
	G1/4	pneumatico amplificato	molla pneumomeccanica	1100	8	5	7	6	4	0,54	AF-2701
	G3/8	pneumatico amplificato	molla pneumomeccanica	1500	10	5	7	6	4	0,52	AF-2706

G1/8

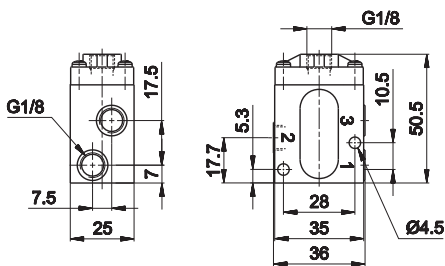

- 1 = Alimentazione
- 2 = Utilizzo
- 3 = Scarico

G1/4 - G3/8

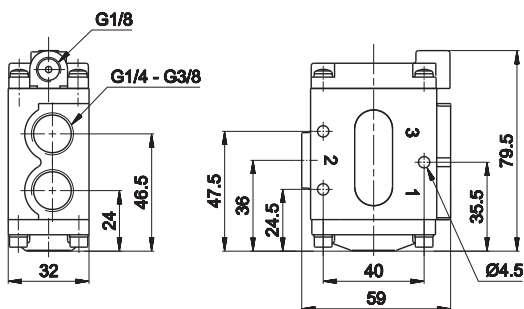

- 1 = Alimentazione
- 2 = Utilizzo
- 3 = Scarico

Servovalvole G1/2 - G3/4 - G1 - G1 1/2



3/2 NC G1/2 - G3/4 - G1
 AF-2603
 AF-2610
 AF-2615

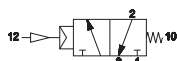

3/2 NC G1 1/2
 AF-2620

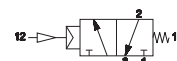

3/2 NO G1/2 - G3/4 - G1
 AF-2603
 AF-2610
 AF-2615



3/2 NO G1 1/2
 AF-2620

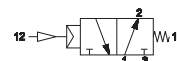

3/2 NC-NO

Attacco	Comando	Ritorno	Portata (Nl/min)	Ø mm	Tempo (ms)		Pressione bar		Peso Kg	Codice
					Ecc.	Dis.	alimen.	comando		
G1/2	pneumatico amplificato	molla pneumomeccanica	5400	15	7	10	6	4	1,27	AF-2603
G3/4	pneumatico amplificato	molla pneumomeccanica	6500	19	7	10	6	4	1,10	AF-2610
G1	pneumatico amplificato	molla pneumomeccanica	13500	25	10	12	6	4	1,59	AF-2615
G1 1/2	pneumatico amplificato	molla pneumomeccanica	35000	39	36	15	6	4	2,19	AF-2620

G1/2 - G3/4 - G1

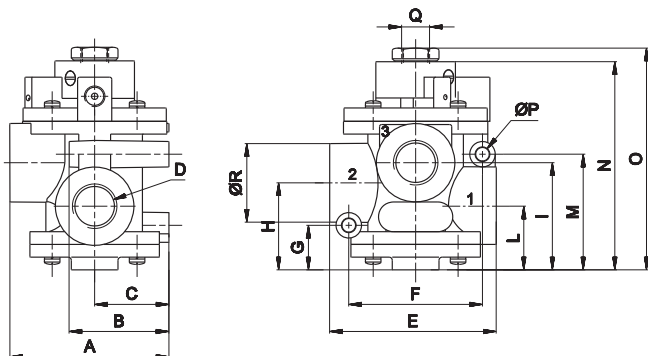

1 = Alimentazione
 2 = Utilizzo
 3 = Scarico

	A	B	C	D	E	F	G	H	I	L	M	N	O	P	Q	R
G1/2	75	47	35	G1/2	78,5	63	21	41	50,5	30	54,5	100	105	6,4	G1/4	37
G3/4	75	47	35	G3/4	78,5	63	21	41	50,5	30	54,5	100	105	6,4	G1/4	37
G1	88,5	55	40	G1	101	76	25,5	51	64	38	62,5	115	120,5	8,4	G1/4	45

G1 1/2

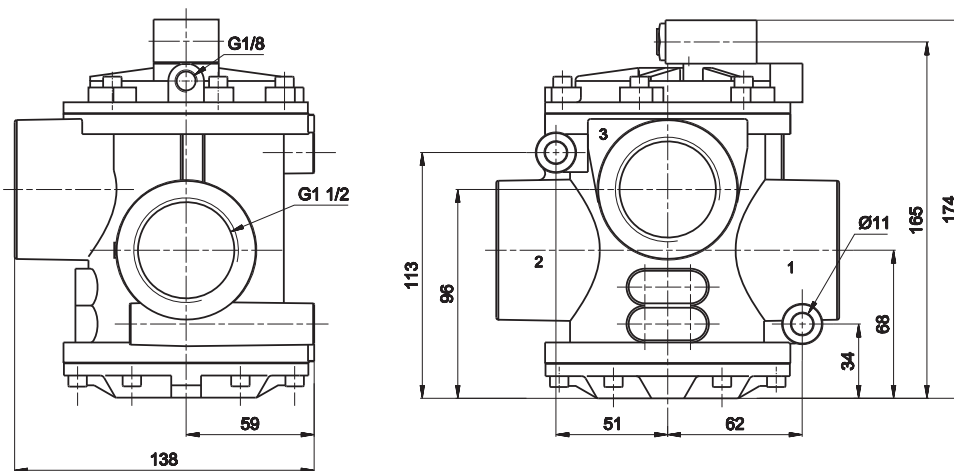

1 = Alimentazione
 2 = Utilizzo
 3 = Scarico

Elettrovalvola 2/2 per soffiaggio G1

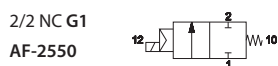

2/2 NC

Attacco	Comando	Ritorno	Portata (NI/min)	Ø mm	Tempo (ms)		Pressione bar		Peso Kg	Codice		
					Ecc.	Dis.	alimen.	comando				
G1	elettrico amplificato	molla pneumomeccanica	16000	25	23	55	2	10	-	-	1,06	AF-2550
G1	elettrico amplificato	molla pneumomeccanica	16000	25	23	55	2	10	-	-	1,06	AF-2551
G1	elettrico amplificato	molla pneumomeccanica	16000	25	23	35	-	-	6	4	1,06	AF-2552

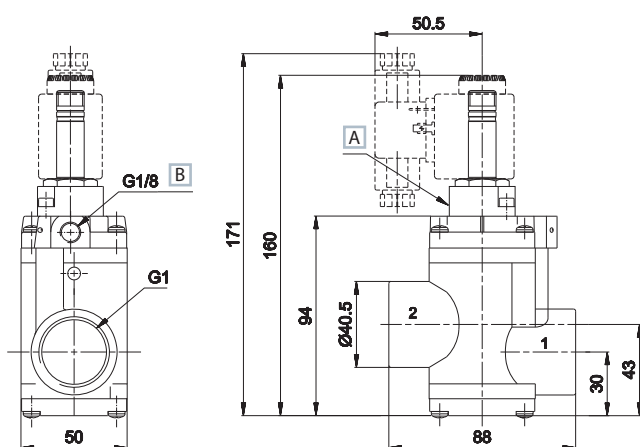

1 = Alimentazione
2 = Utilizzo

A Comando manuale AF-2551
B Servoalimentazione esterna del pilota AF-2552

Servoalvola 2/2 per soffiaggio G1

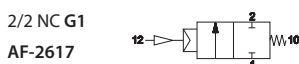

2/2 NC

Attacco	Comando	Ritorno	Portata (NI/min)	Ø mm	Tempo (ms)		Pressione bar		Peso Kg	Codice
					Ecc.	Dis.	min.	max.		
G1	pneumatico amplificato	molla pneumomeccanica	16000	25	12	25	6	4	1	AF-2617

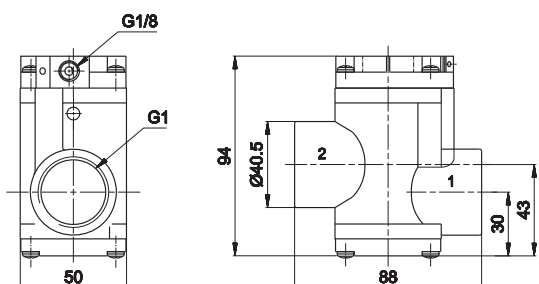

1 = Alimentazione
2 = Utilizzo

Le elettrovalvole sono fornite senza bobina, connettore e ghiera di bloccaggio