

40

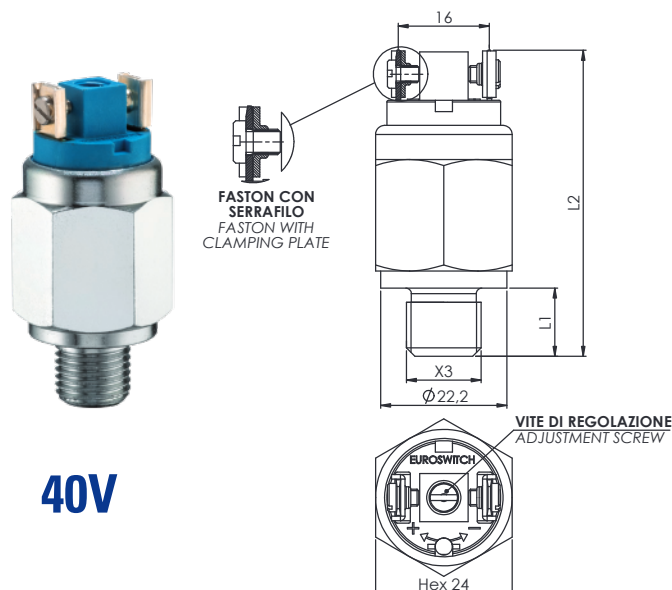

40V

CODICE - PART NUMBER

contatto elettrico - electrical contact		Campo di regolazione / Setting range bar	Tolleranza a 20°C / Tolerance at 20°C bar
norm. aperto norm. open	norm. chiuso norm. closed		
40(V) 1 ▲ ● ■ 6	40(V) 2 ▲ ● ■ 6	50 - 150	± 2 ÷ 10
40(V) 1 ▲ ● ■ 7	40(V) 2 ▲ ● ■ 7	100 - 300	± 5 ÷ 15

(V) = versione faston con serrafilo / faston with clamping plate

▲ Materiale Corpo Case Material

0 Acciaio Zincato	0 Zinc plated steel case
2 Acciaio inox AISI 316 *	2 Stainless steel AISI 316 *
5 Acciaio inox AISI 303 *	5 Stainless steel AISI 303 *

* Standard G1/4" cilindrico * Standard G1/4" cylindrical

● Filetti (X3) Threads (X3) L1 L2 (mm)

1 1/8" Gas conico	1 1/8" Gas conical	10	52
2 1/4" Gas conico	2 1/4" Gas conical	12	54
3 M10x1K conico	3 M10x1K conical	10	52
H 1/4" Gas cilindrico	H 1/4" Gas cylindrical	12	54

Contatti elettrici	Argento AgNi, (a richiesta dorati)
Condizione elettrica	N.A. (bordeaux) o N.C. (blu)
Max tensione commutabile	48 V ac / dc
Max corrente commutabile	0.5 A (a richiesta 2A)
Max temperatura fluido	100° C
Vita meccanica	10 ⁵ operazioni (10-300 bar)
Vita elettrica	10 ⁵ operazioni
Max pressione di sicurezza	800 bar
Max pressione di lavoro	450 bar
Tipo di azionamento	1B
Grado di protezione	IP 00 (vedi pag. 18-20 per cappucci e connettori di protezione)
■ Tenuta	NBR + Teflon (vedi pag. 17)
Peso	~ 75 g

Electric contacts	Silver AgNi, (gold plated on request)
Electrical condition	N.O. (bordeaux) or N.C. (blue)
Max switched voltage	48 V ac / dc
Max switched current	0.5 A (2A on request)
Max fluid temperature	100° C
Mechanical working life	10 ⁵ operations (10-300 bar)
Electrical working life	10 ⁵ operations
Max Overpressure limit	800 bar
Max working pressure	450 bar
Action type	1B
Protection degree	IP 00 (see pages 18-20 for protection caps and connectors)
■ Seal	NBR+Teflon /see page 17)
Weight	~ 75 g