

## Magnet catch

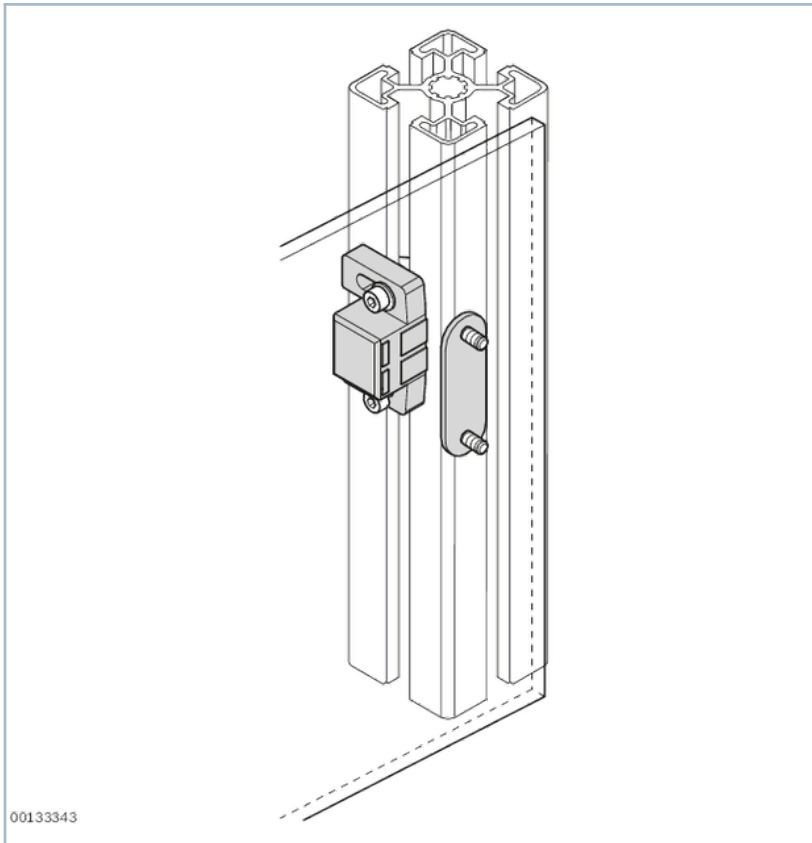

- The magnet catch prevents doors and flaps from banging or being unintentionally opened
- Elongated holes to compensate for different surface element thicknesses

## Product description



## Technical data

No.		3842558323	3842555568	3842516165
Material		PP; white, steel; galvanized	PA; signal gray RAL 7004 Galvanized steel	PA; black Galvanized steel

<p><math>F_C = 20N</math></p>	3 842 558 323
<p><math>F_C = 40N</math></p>	3 842 555 568

# Dimensions

## Magnet catch slot 6

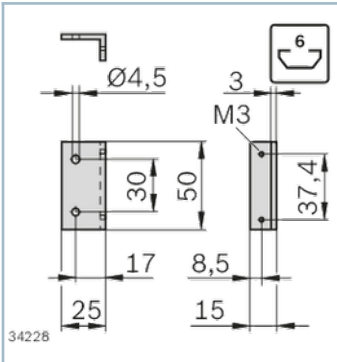

## Magnet catch slot 6

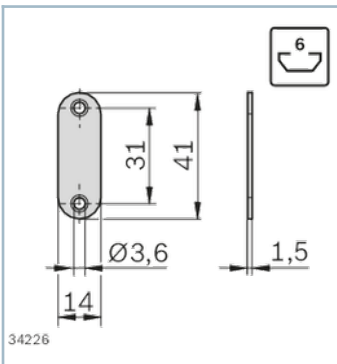

## Magnet catch slot 6

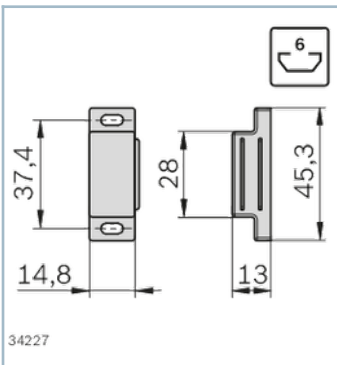

## Magnet catch slot 8, 10

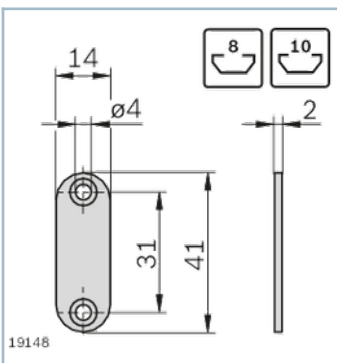

## Magnet catch slot 8, 10

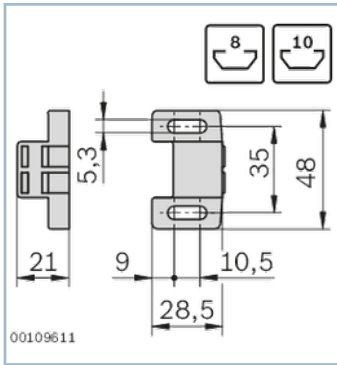

## Accessories

## Required accessories

Cylinder bolt ISO 4762

Washer

T-nut

## Delivery notes

FS1



## Scope of delivery

Magnet catch slot 6	Incl. counterpiece, bracket, fastening material (FS)
Magnet catch slot 8, 10	Incl. counterpiece
Magnet catch slot 8, 10	

# Ordering codes

	Groove	FS	No.
Magnet catch slot 6	6	2xFS1	3842558323
Magnet catch slot 8, 10	8, 10		3842555568
Magnet catch slot 8, 10	8, 10		3842516165