

PRESSOSTATO A MEMBRANA ≤ 250V  
DIAPHRAGM PRESSURE SWITCH ≤ 250V

# 31-31V



A richiesta disponibile la versione certificata ATEX / IECEx  
Version ATEX / IECEx available on request



**31**

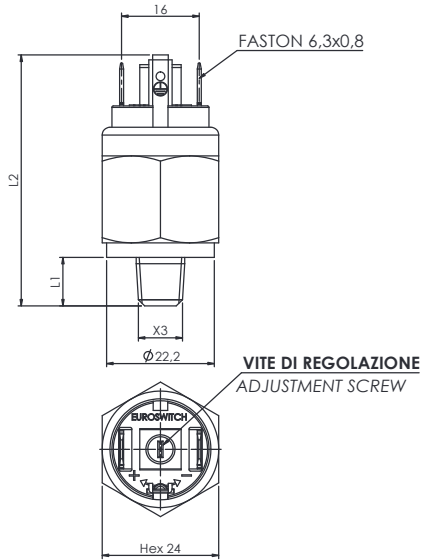

**31V**

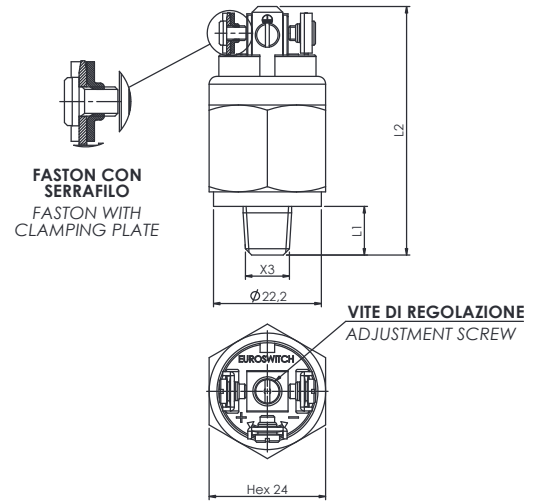

**CODICE - PART NUMBER**

contatto elettrico - electrical contact		Campo di regolazione / Setting range bar	Tolleranza a 20°C / Tolerance at 20°C bar
norm. aperto norm. open	norm. chiuso norm. closed		
31(V) 1 ▲ ● ■ 0	31(V) 2 ▲ ● ■ 0	0.1 - 1	± 0.1
31(V) 1 ▲ ● ■ A	31(V) 2 ▲ ● ■ A	0.2 - 2	± 0.15
31(V) 1 ▲ ● ■ 1	31(V) 2 ▲ ● ■ 1	1 - 5	± 0.3
31(V) 1 ▲ ● ■ 2	31(V) 2 ▲ ● ■ 2	1 - 10	± 0.5
31(V) 1 ▲ ● ■ 3	31(V) 2 ▲ ● ■ 3	10 - 20	± 1.0
31(V) 1 ▲ ● ■ 4	31(V) 2 ▲ ● ■ 4	20 - 50 <sup>(1)</sup>	± 2.0

<sup>(1)</sup> Versione fornibile solo con corpo in acciaio zincato / Inox AISI - Available only with body Zinc plated or Stainless steel

▲ Materiale Corpo Case Material	● Filetti (X3) Threads (X3)	L1	L2 (mm)	■ Membrane (vedi pag. 17) Diaphragms (see page 17)
0 Acciaio Zincato 0 Zinc plated steel case	1 1/8" Gas conico 1 1/8" Gas conical	10	51	1 NBR
1 Ottone 1 Brass	2 1/4" Gas conico 2 1/4" Gas conical	12	53	2 FKM (standard)
2 Acciaio inox AISI 316 * 2 Stainless steel AISI 316 *	3 M10x1K conico 3 M10x1K conical	10	51	3 EPDM CH
5 Acciaio inox AISI 303 * 5 Stainless steel AISI 303 *	4 M12x1,5 Cilindrico 4 M12x1,5 cylindrical	9	50	4 CR
	5 1/8" NPT 5 1/8" NPT	10	51	5 Silicone
	6 1/4" Gas cilindrico 6 1/4" Gas cylindrical	9,7	50,7	6 HNBR
	8 M10x1 cilindrico 8 M10x1 cylindrical	9,5	50,5	
	G 1/8" Gas cilindrico G 1/8" Gas cylindrical	10	51	

\* Standard G1/4" cilindrico \* Standard G1/4" cylindrical

Contatti elettrici	Argento AgNi, (a richiesta dorati)
Condizione elettrica	N.A. (bordeaux) N.C. (blu)
Max tensione commutabile	250 V
Max corrente commutabile	0,5 A
Max temperatura fluido	80° a 120°C (in funzione della membrana)
Vita meccanica	10 <sup>6</sup> operazioni
Vita elettrica	10 <sup>5</sup> operazioni
Max pressione di sicurezza	Acciaio zincato / Inox 300 bar Ottone 80 bar
Max pressione di lavoro	Acciaio zincato / Inox 150 bar Ottone 40 bar
Tipo di azionamento	1B
Grado di protezione	IP 00 (vedi pag. 18-20 per cappucci e connettori di protezione)
Peso	~ 65 g

Electric contacts	Silver AgNi, (gold plated on request)
Electrical conditions	N.O. (bordeaux) N.C. (blu)
Max switches voltage	250 V
Max switches current	0,5 A
Max fluid temperature	80° to 120°C (depending on diaphragm)
Mechanical working life	10 <sup>6</sup> operations
Electrical working life	10 <sup>5</sup> operations
Max Overpressure limit	Zinc plated steel / Stainless steel 300 bar Brass 80 bar
Max Working pressure	Zinc plated steel / Stainless steel 150 bar Brass 40 bar
Action type	1B
Protection degree	IP 00 (see pages 18-20 for protection caps and connectors)
Weight	~65 g

Per un corretto impiego vedere le note generali del catalogo pressostati Euroswitch 20-03-1, pag. 11-15. For a correct use please refer to "General Notes" in the pressure switches Euroswitch catalogue 20-03-1, p. 11-15.  
L'Azienda si riserva la facoltà di apportare modifiche tecniche ai prodotti o di cessarne la produzione senza obbligo di preavviso. The Company reserves the right to modify the technical features of the products or halt production at any time without notice.